

Centrifugal Slurry Pumps

86 311 66692398

www.slurrypump.co

sales@slurrypump.co

Shijiazhuang Minerals Equipment Co., Ltd (CNSME®)

No. 260 Huai An West Road, Qiaoxi District, Shijiazhuang, Hebei, China.



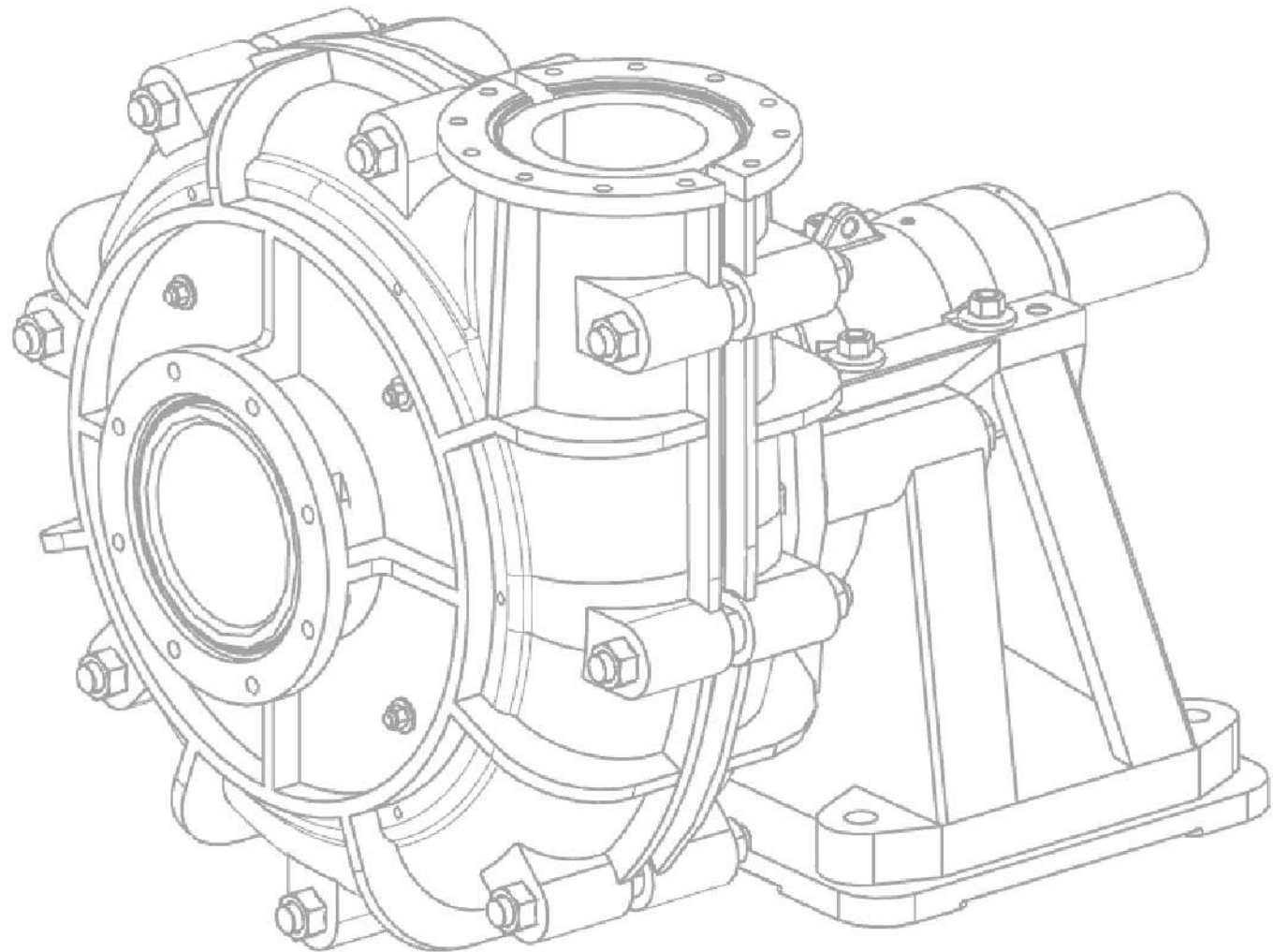

Company Profile

Shijiazhuang Minerals Equipment Co., Ltd, also known as CNSME®, is a professional Slurry Pumps and parts manufacturer based in the city of Shijiazhuang, Hebei, China. With nearly 30 years of experience dedicated to the pump industry, we provide expert advice, reliable products, and responsible technical service to our customers from all over the world.

We stock an extensive range of pumps and main spare parts to ensure a shorter lead time and faster delivery to the user's site to reduce the downtime to its minimum and save the total ownership cost.

CNSME® is working its best to become one of the world class suppliers of trusted slurry pumps and parts to serve global mining, minerals processing, sand and aggregate and other related industrial sectors.



Our Vision

- To become one of the most trustworthy providers of slurry pumping solutions

Our Mission

- Solve your tough industrial pumping challenges with our technical expertise
Support your slurry pumping needs with our excellent products

Our Values

- Improvement, Innovation, Reliability and Responsibility

CONTENTS

CNSME® is specializing in delivering and supporting slurry equipment solutions for mining and minerals processing industries.

HORIZONTAL PUMPS

01-06 **SH(R) Series**
Heavy Duty Slurry Pumps

07-10 **SHP/SHPP Series**
Severe Duty High Pressure Slurry Pumps

11-14 **SL(R) Series**
Light Duty Slurry Pumps

15-18 **SG(H) Series**
Sand Gravel Pumps

19-22 **SHF/SMF/SLF Series**
Froth Pumps

23-26 **MD Series**
Mill Underflow Pumps

VERTICAL PUMPS

27-28 **SV(R) Series**
Vertical Sump Pumps

29-30 **STC Series**
Vertical Non-Clog Pumps

31-32 **SF Series**
Vertical Tank Froth Pumps

● SH(R) Series

Overview

The heavy duty SH(R) pump range is designed to perform continuous pumping of highly abrasive slurries. This range of pumps have been proved successful in processes from hydrocyclone feed to regrind, flotation and tailings in minerals processing plants as well as other industrial applications.

Specifications

Discharge size range: 25mm to 450mm [1" to 18"]

Flowrates to: 5000m³/hr [22,000GPM]

Heads to: 73m [240ft]

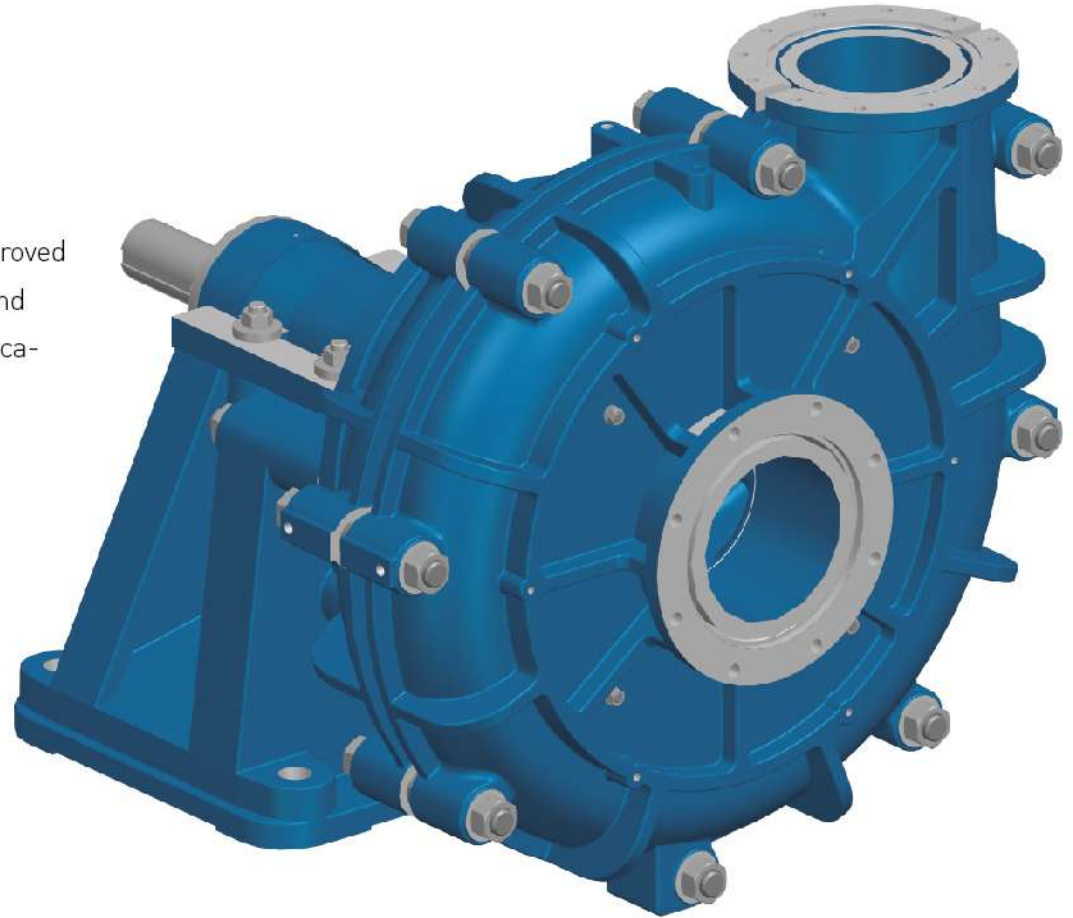

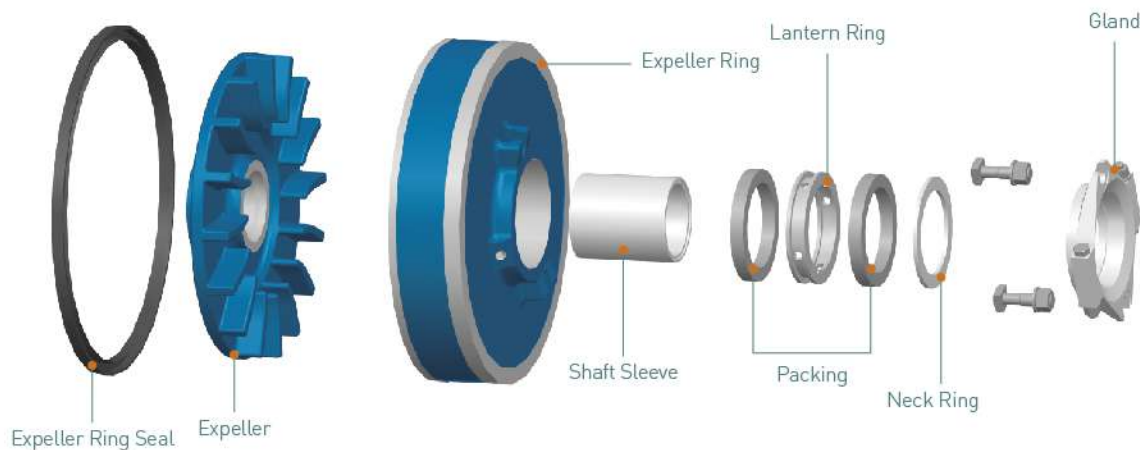

Figure 1: Expeller Seal Assembly

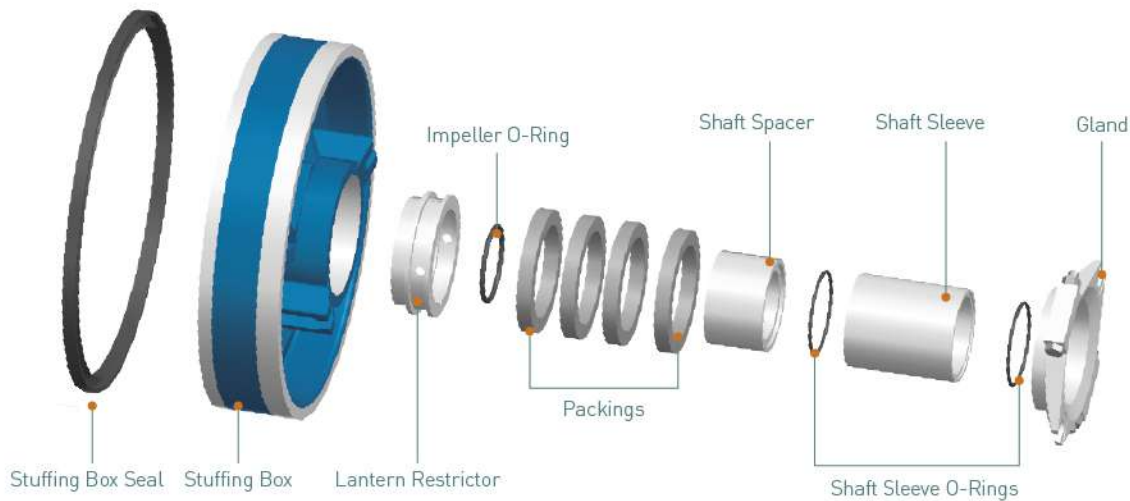

Figure 2: Gland Seal Assembly

Key Features

Heavy duty construction with through-bolt design provides ease of maintenance and minimal downtime

Large diameter, slow turning, high efficiency impellers designed to achieve maximum wear life and low operating costs

Cartridge-style bearing assembly allows for maintenance in a clean environment without removal of the pump, resulting in reliable operation and prolonged bearing life

Diverse selections of shaft seals tailored to each specific application

Expeller Seal Assembly -- Dry Seal: no need for flushing water (Figure 1)

Gland Seal Assembly -- Wet Seal: clean flushing water is necessary (Figure 2)

**Improved "HS1" type Hi-Seal as Options to the traditional Expeller & Gland Seal assembly

Interchangeable wet-end parts between chrome alloys and elastomers (Figure 3) reduces overall maintenance costs

Upgraded technology of "WRT" type of impeller and throat-bush combination (Figure 4) designed to enhance efficiency, lower NPSHr and improve wear performance

CNSME®

Centrifugal Slurry Pumps

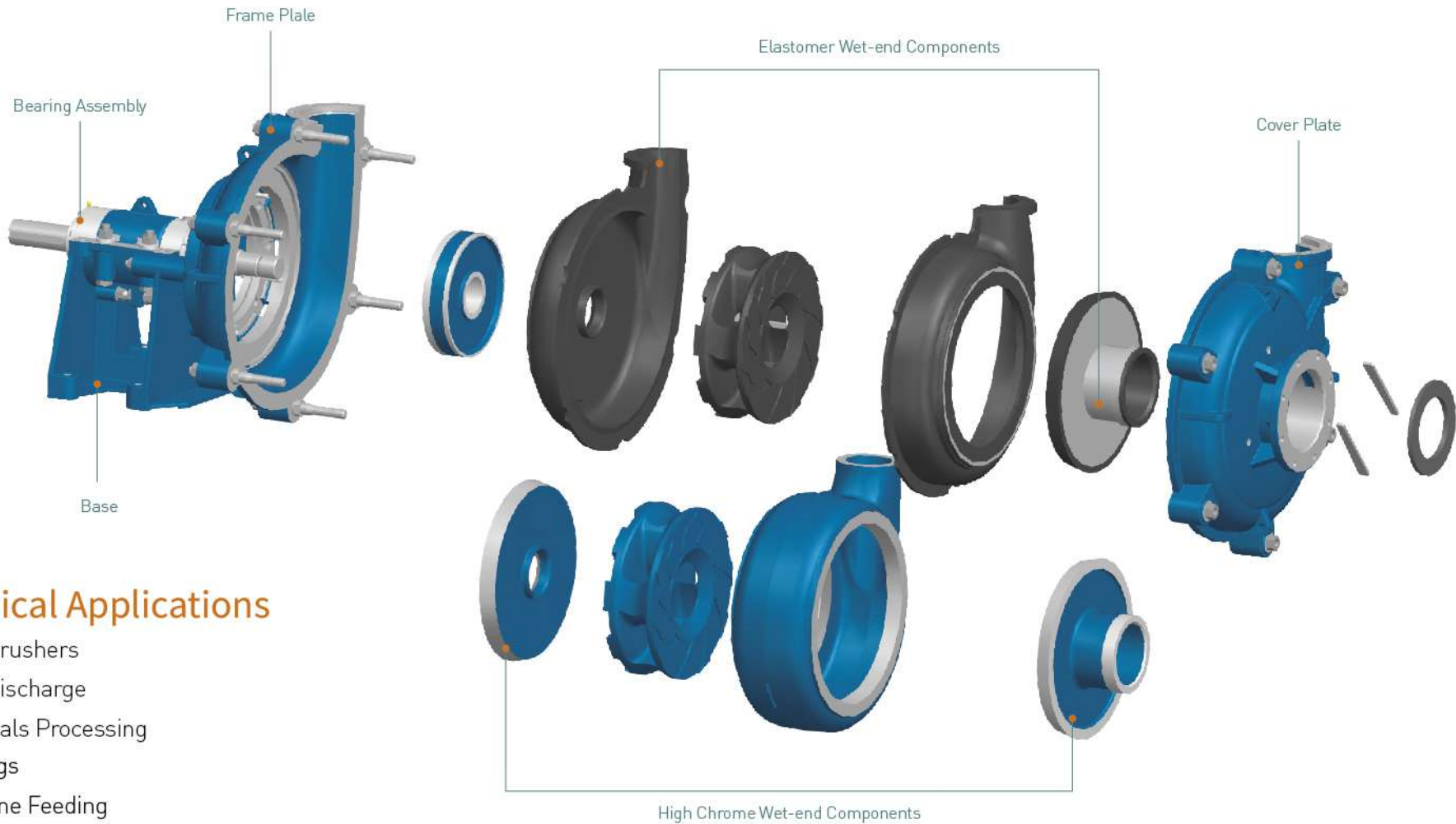

Typical Applications

- Wet Crushers
- Mill Discharge
- Minerals Processing
- Tailings
- Cyclone Feeding
- Coal Preparation

Figure 3: High Chrome & Elastomer Wet-end Components

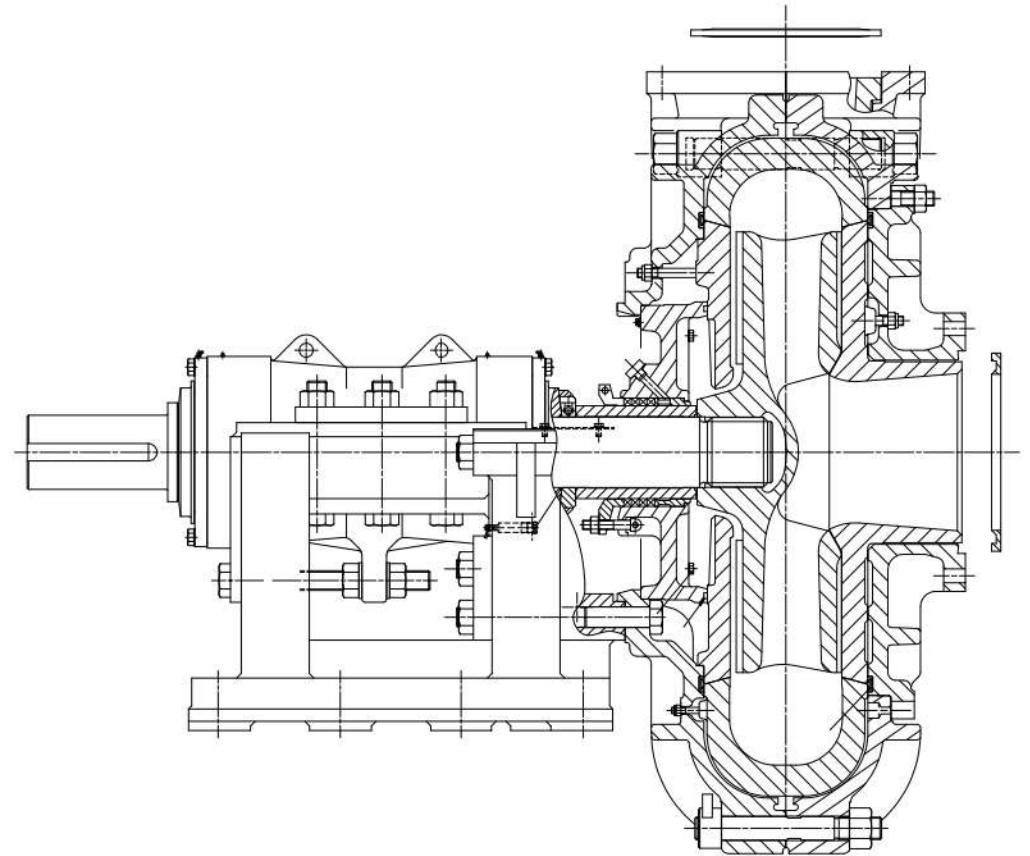
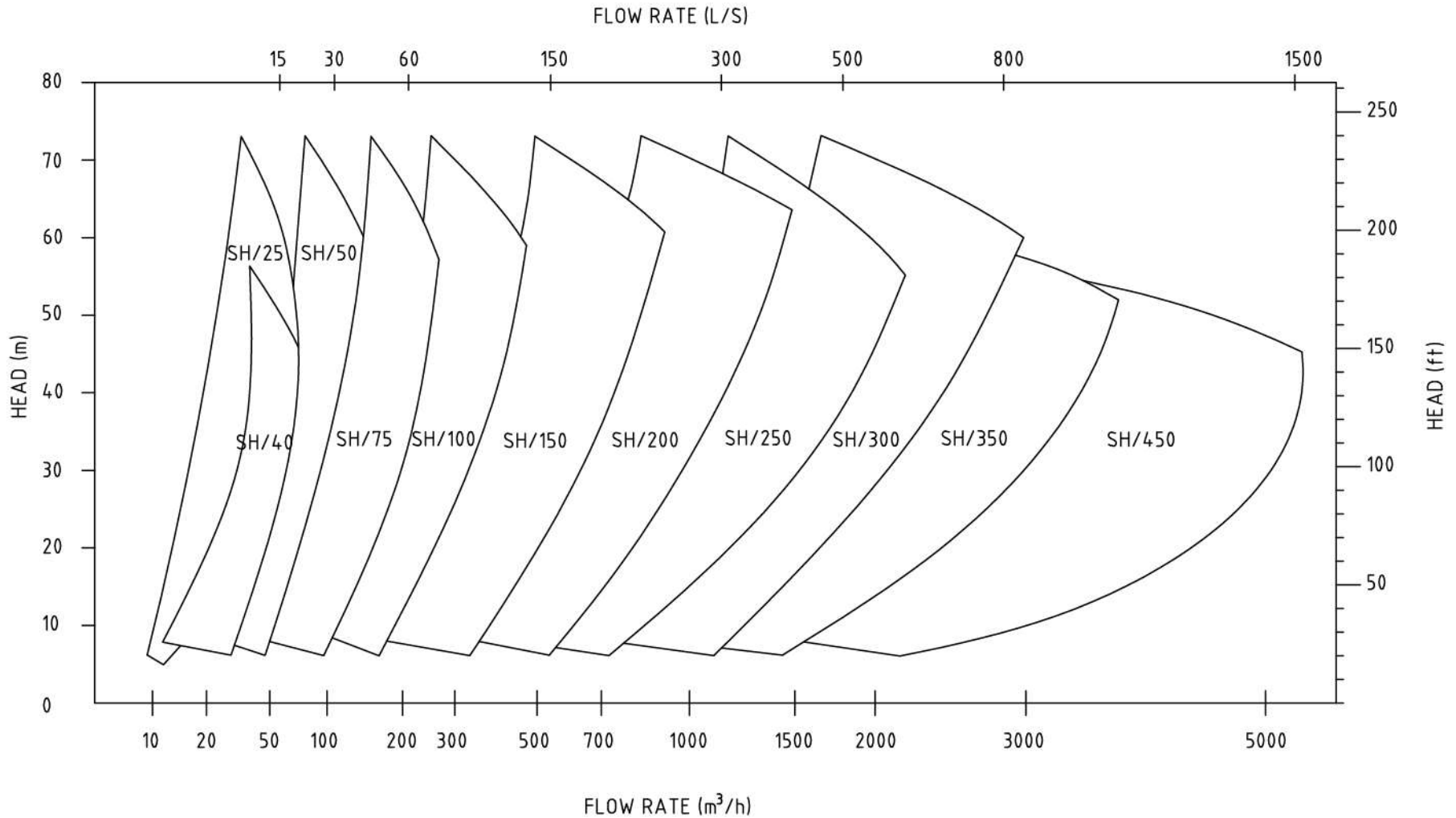

Figure 4: "WRT" Design of Impeller and Throatbush Combination

Performance Coverage for Quick Selection

SH(R) Series



Performance Coverage for Quick Selection

SH(R) with WRT Design

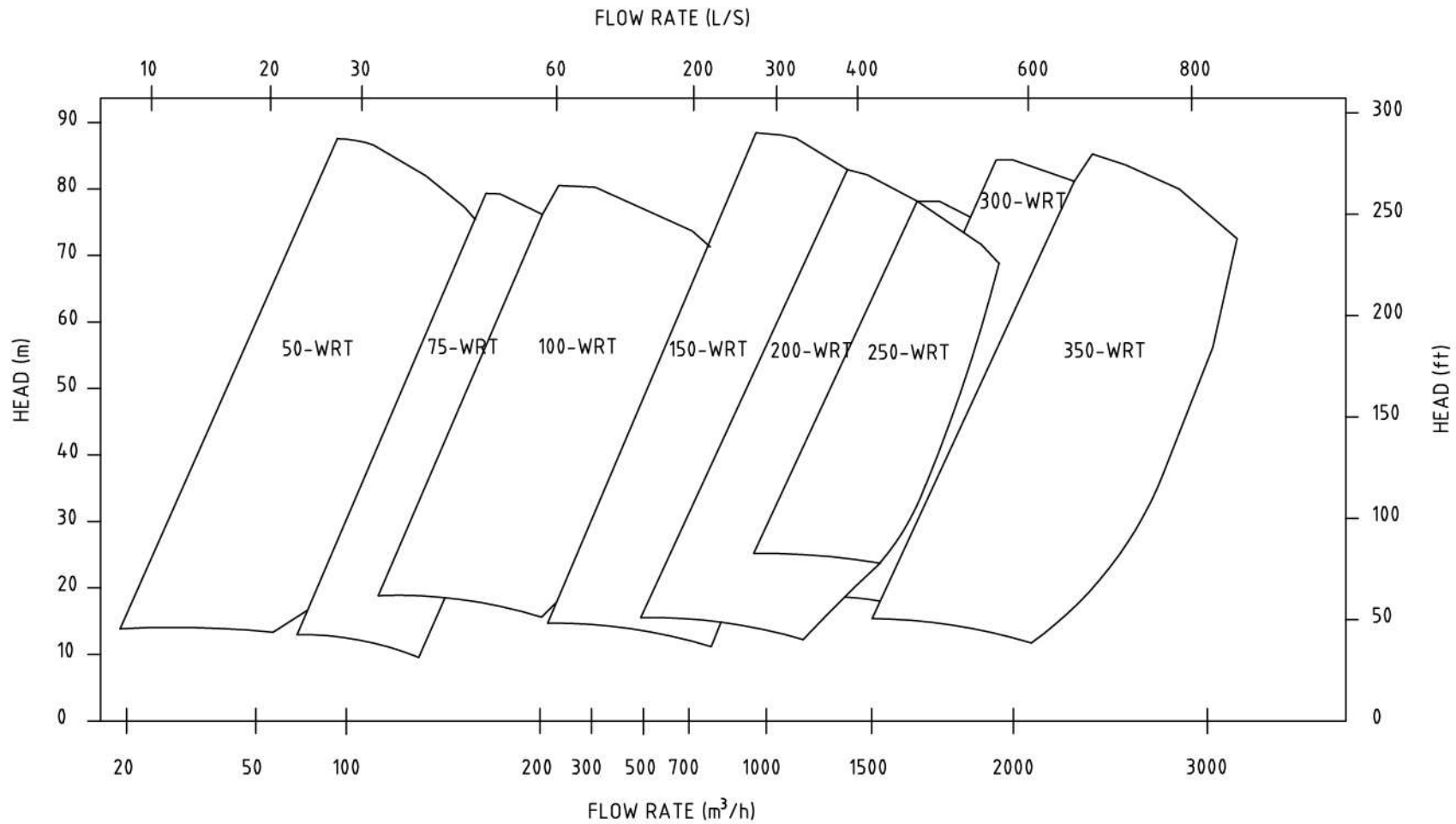

● SHP/SHPP Series

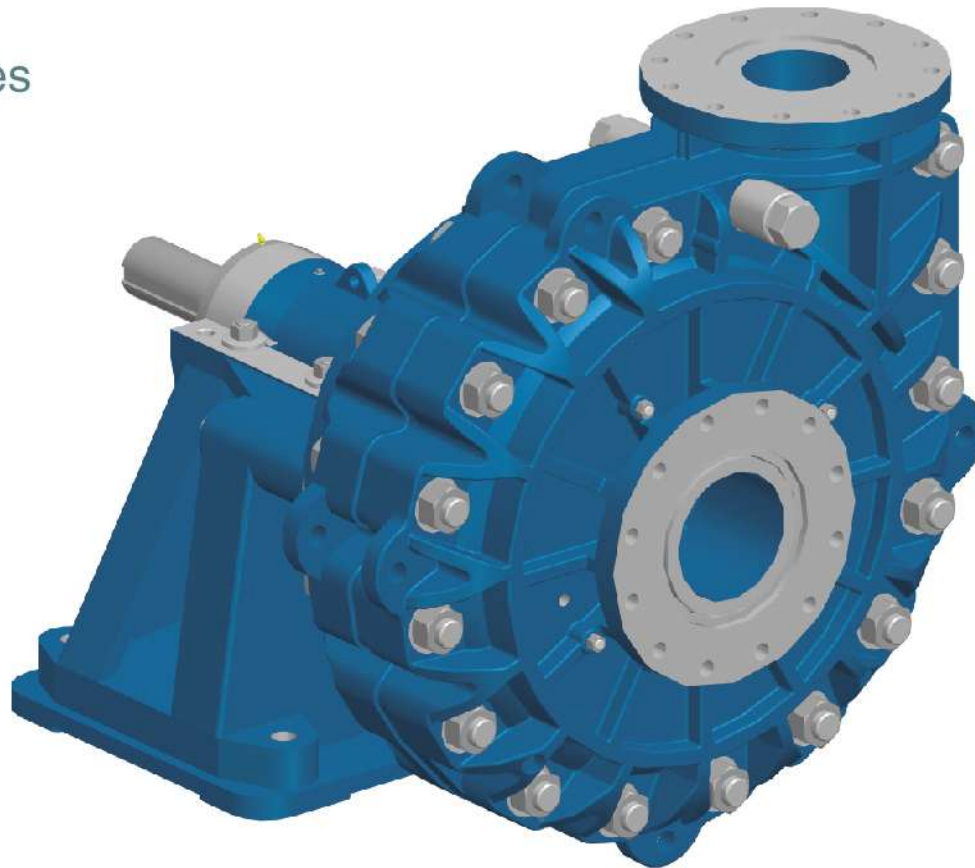

Overview

SHP/SHPP range high pressure pump offers the same features and benefits as the SH pump, but the higher pressure capability allows the user to operate several pumps in series all consolidated into one pump house.

Specifications

Discharge size range: 100mm to 450mm [4" to 18"]

Flowrates to: 5000m³/hr [22,000GPM]

Heads to: 73m [240ft]

Performance Coverage for Quick Selection

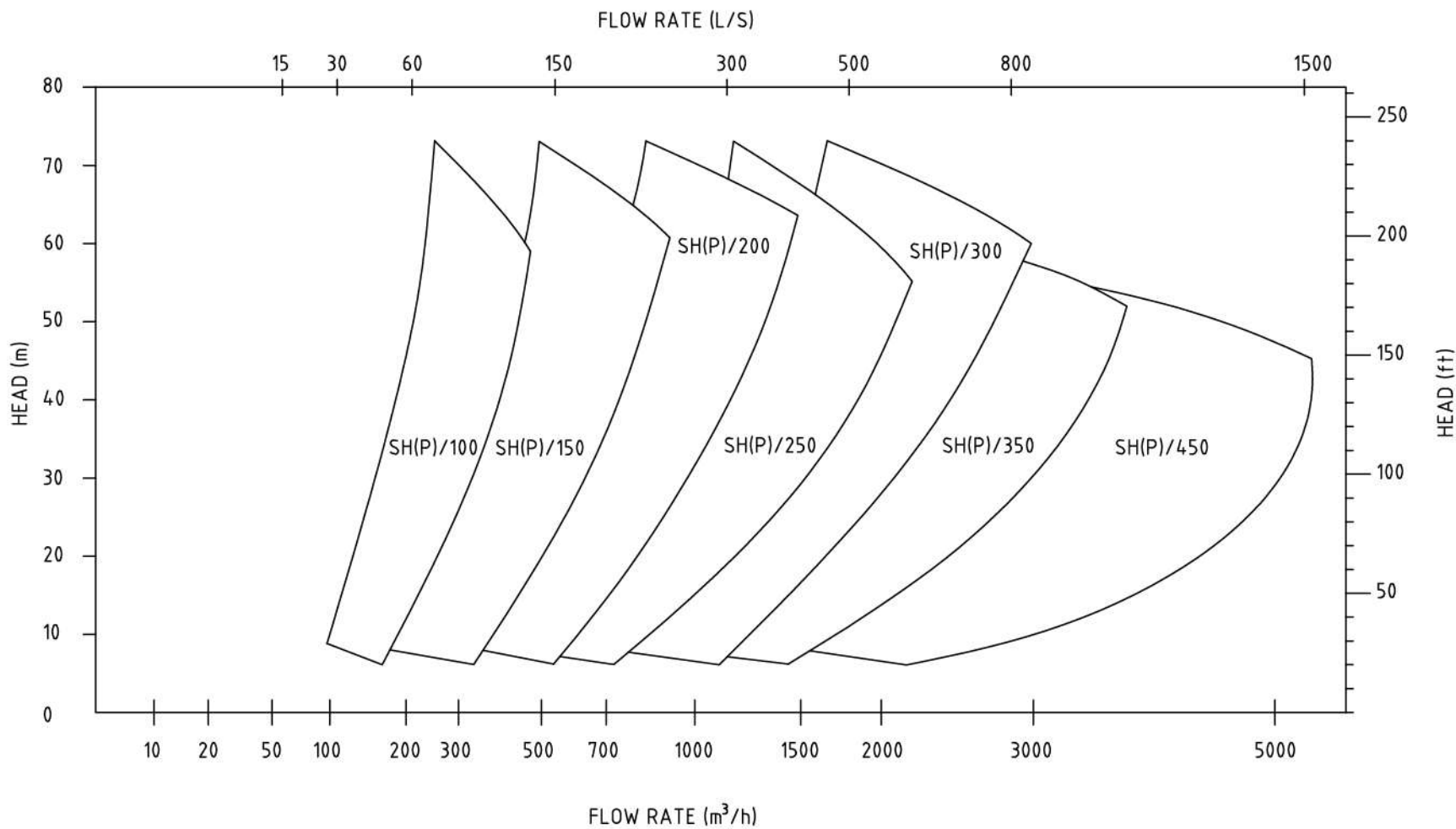

CNSME®

Centrifugal Slurry Pumps

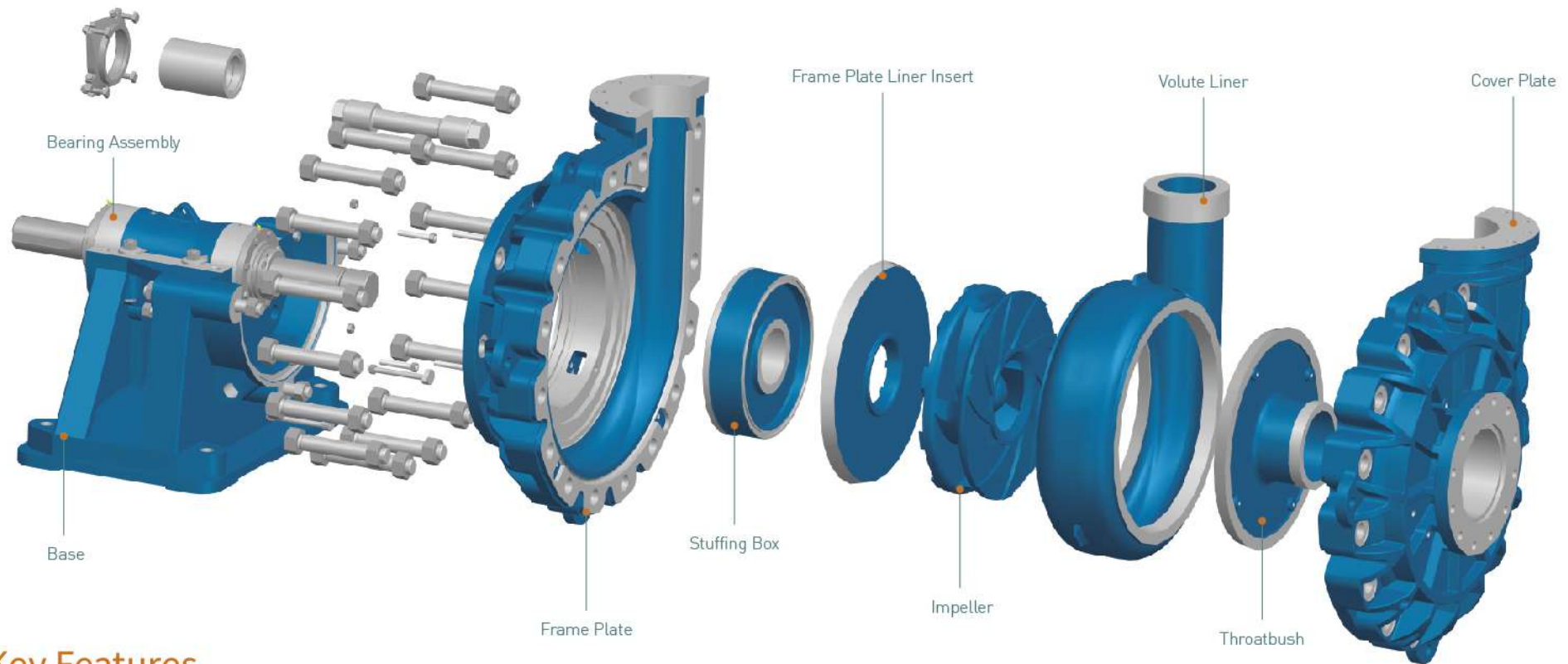

Key Features

- Multi-stage high pressure operation to 6.9Mpa
- Heavy duty construction with through-bolt design provides ease of maintenance and minimal downtime
- Ductile iron outer casings provide durability, strength, safety, and long service life
- Large diameter, slow turning, high efficiency impellers designed to achieve maximum wear life and low operating costs
- Large, open internal passages reduce internal velocities, maximize wear life
- Minimal shaft/impeller overhang reduces shaft deflection and increases packing life and lower operating costs
- Cartridge-style bearing assembly allows for maintenance in a clean environment without removal of the pump, resulting in reliable operation and prolonged bearing life

Typical Applications

- Coarse Tailings
- Minerals Concentrate
- Phosphoric Acid
- Lime Grinding
- Oil Sands
- Coal

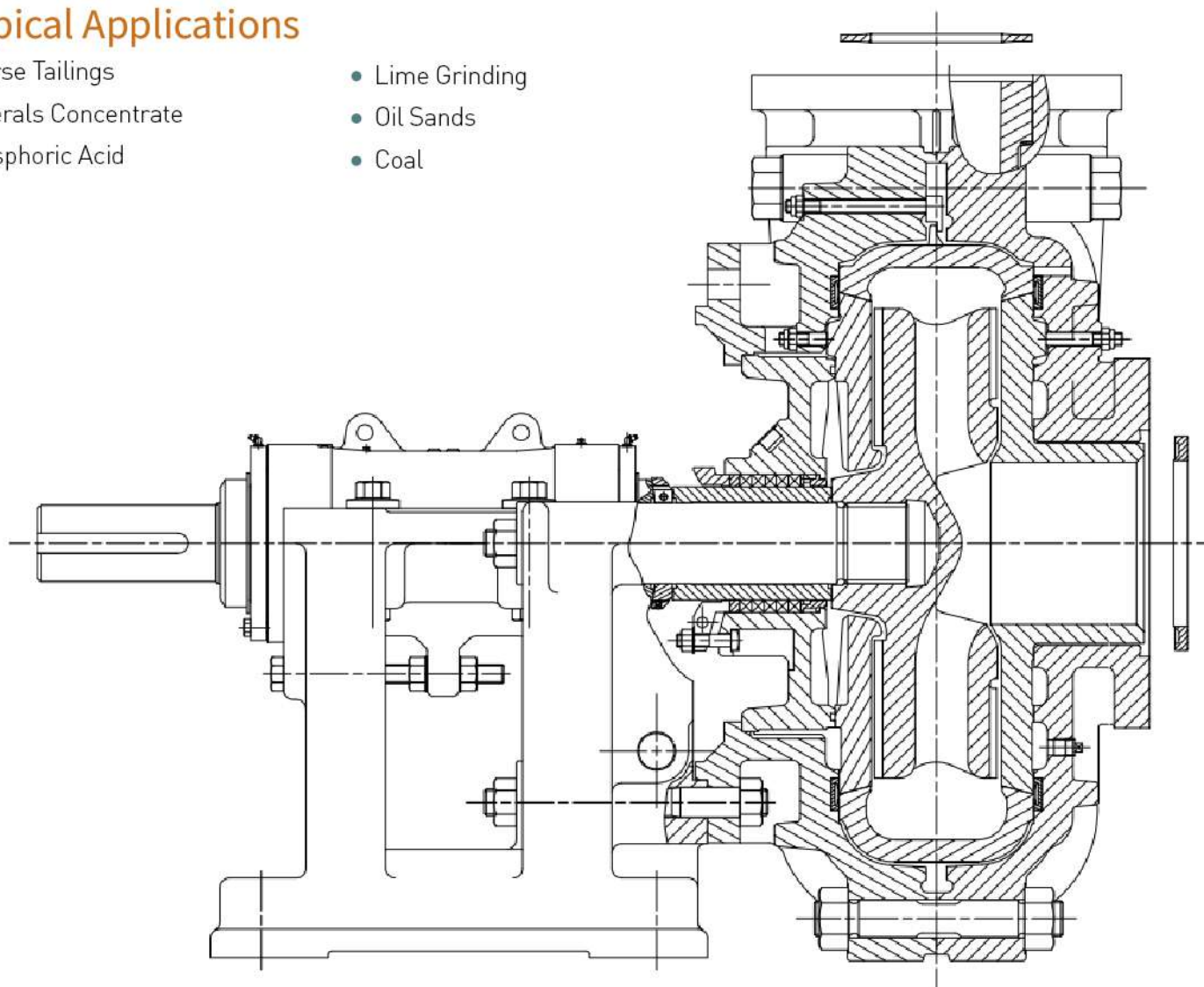

● SL(R) Series

Overview

The CNSME SL(R) series pumps are light duty for medium to lower heads, which incorporate the same design points as the SH(R) pump with higher efficiency impellers at more economical initial costs. SL(R) series provides the widest range of hydraulics from 20mm to 650mm discharge sizes. The 20mm pump is perfect for laboratory use or for demonstration.

Specifications

Discharge size range: 20mm to 650mm [0.75" to 26"]
Flowrates to: 10225m³/hr [45,000GPM]
Heads to: 55m [180ft]

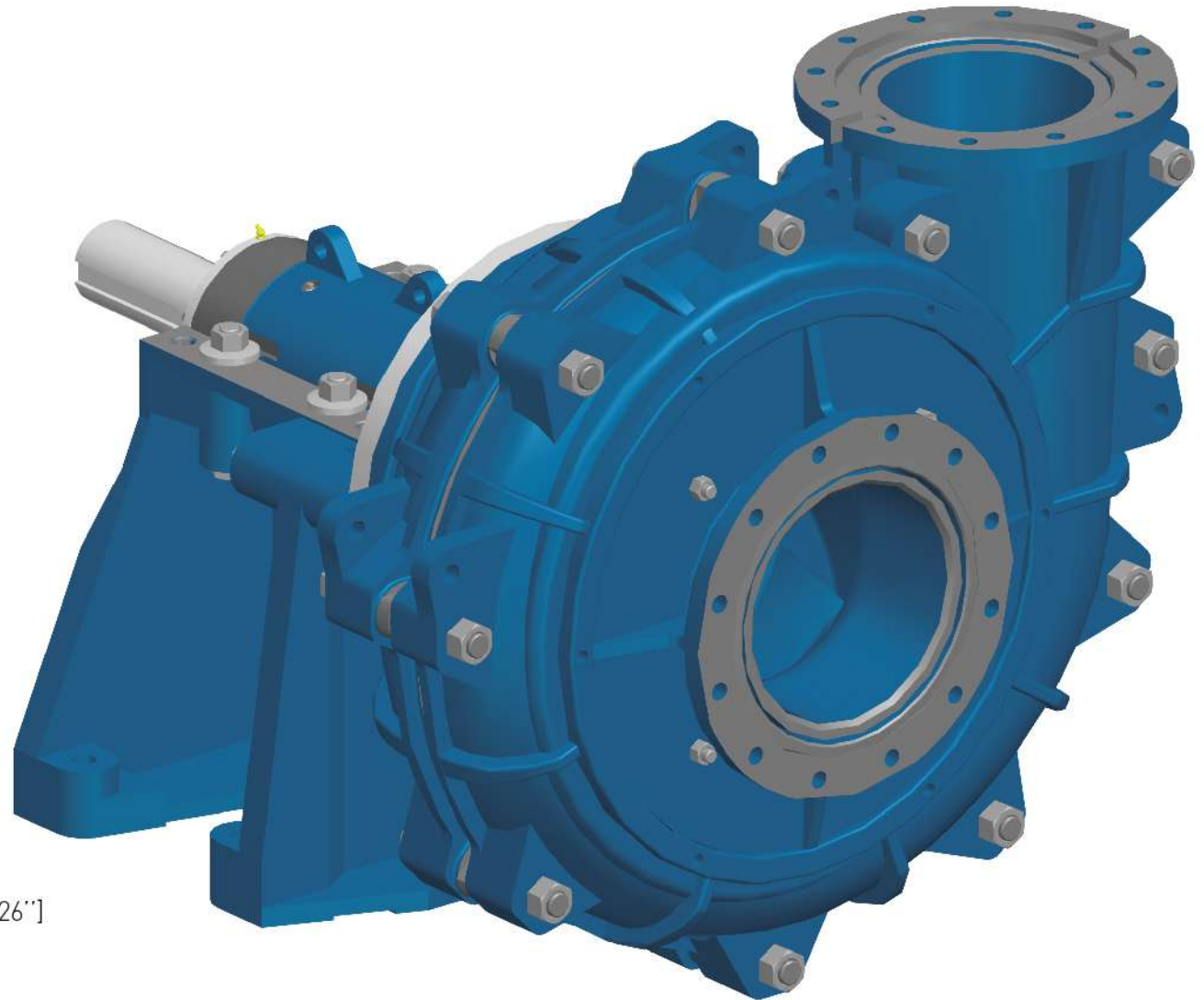

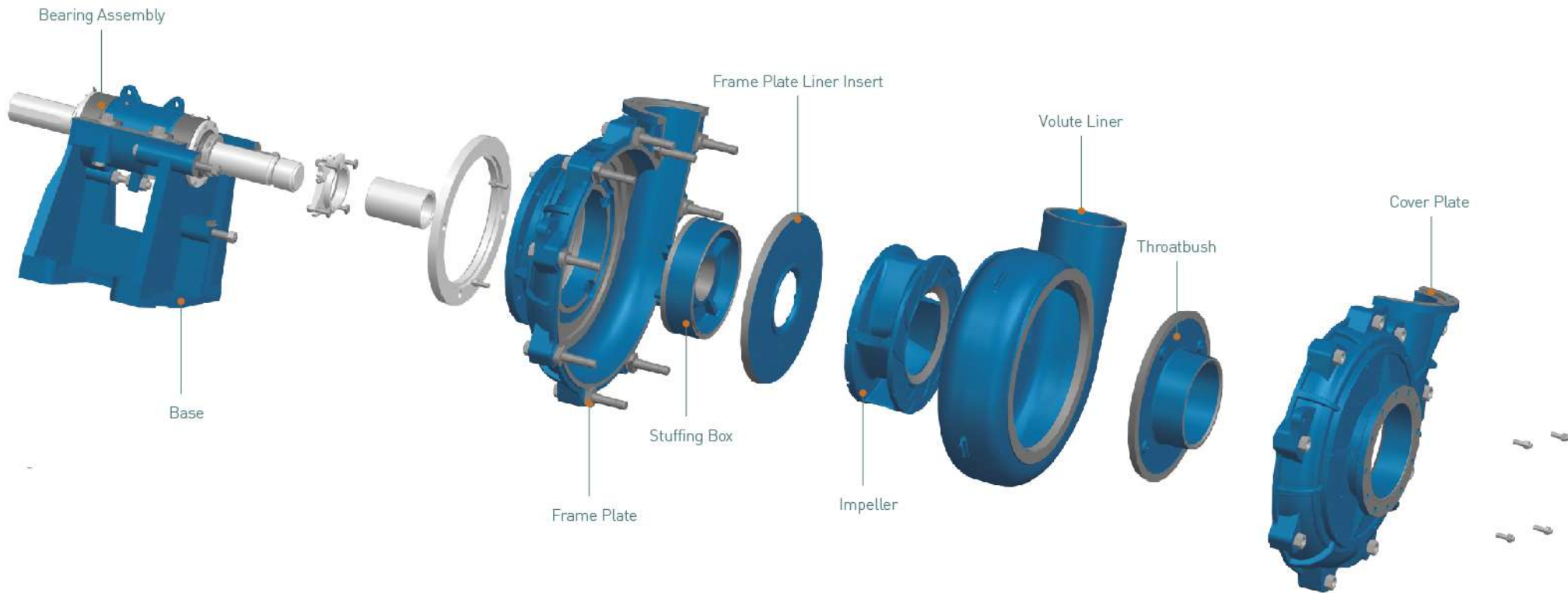

Performance Coverage for Quick Selection

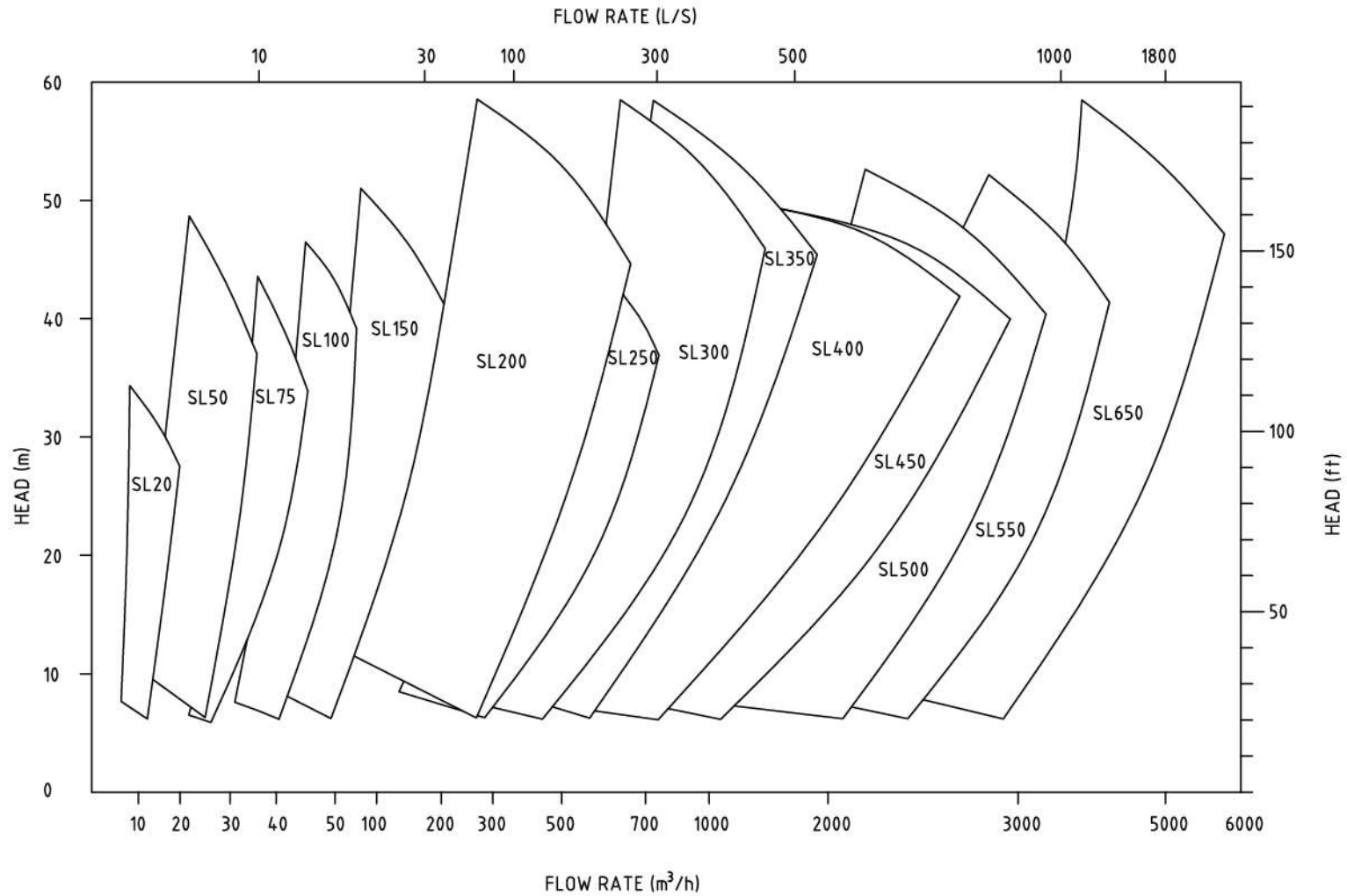

Key Features

Heavy duty construction with through-bolt design provides ease of maintenance and minimal downtime

Large diameter, slow turning, high efficiency impellers designed to achieve maximum wear life and low operating costs

Large, open internal passages designed to reduce internal velocities, maximize wear life and lower operating costs

Thick elastomer or alloy bolt-in liners provide superior corrosion resistance plus offer ease of liner change-out and interchangeability to reduce overall maintenance costs and maximize wear life

Designed for light duties while offering excellent efficiencies

Minimal shaft/impeller overhang reduces shaft deflection and increases packing life

Cartridge-style bearing assembly allows for maintenance in a clean environment without removal of the pump, resulting in reliable operation and prolonged bearing life

Diverse selections of shaft seals tailored to each specific application

Typical Applications

- Ball Mill Discharge
- Heavy Media
- Mineral Sands
- Coarse Sand
- Bottom/fly Ash
- Fine Tailings

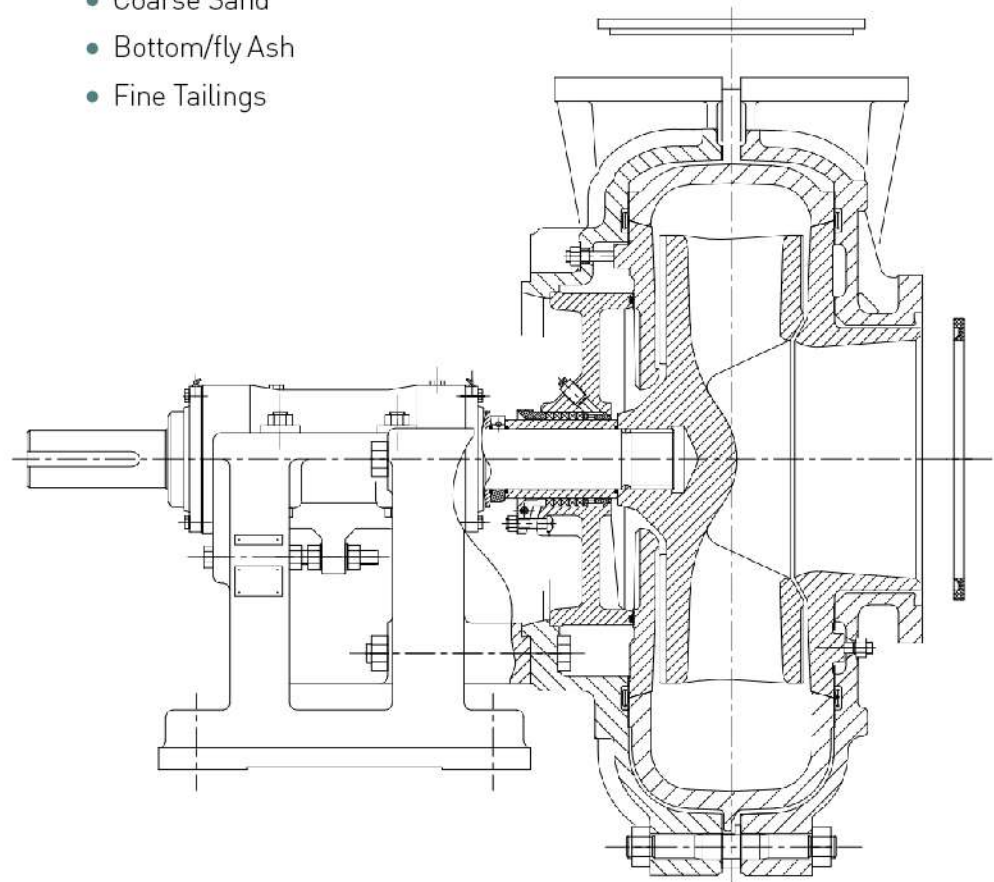

● SG(H) Series

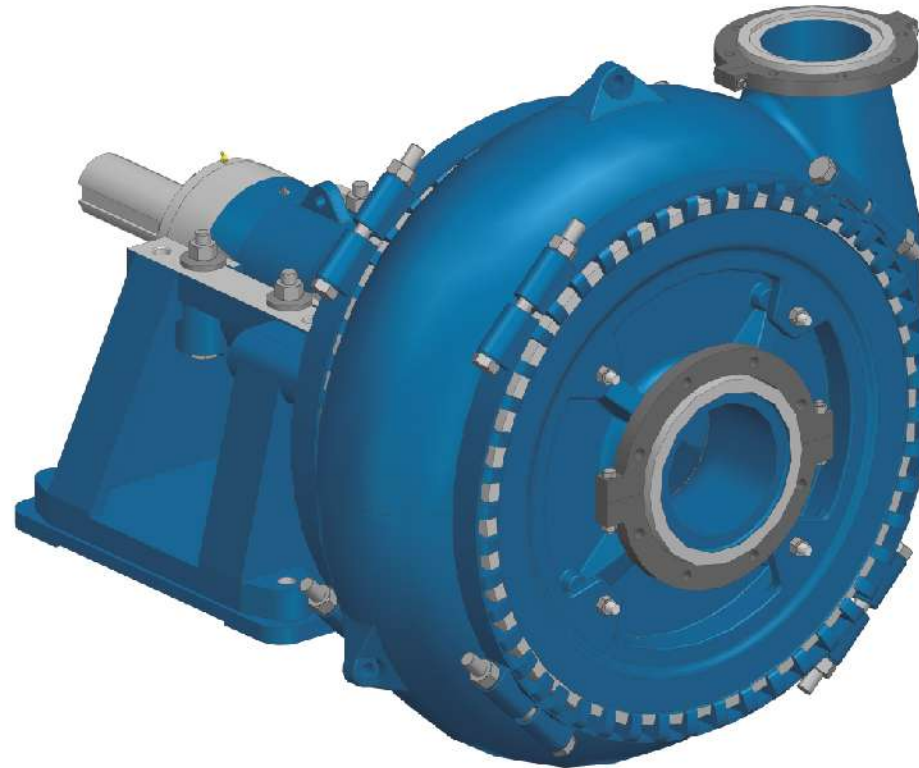

Overview

The SG(H) range of Sand and Gravel pumps is designed to provide continuous pumping of highly abrasive slurries containing large particles at high maintained efficiencies with low maintenance and ownership costs.

The Heavy Duty SG Sand Pump is specifically designed for low head duties such as hopper dredging and barge loading.

The Heavy Duty SGH Gravel Pump is designed for higher head duties such as cyclone feed, long distance pipelines and high static discharge heads.

Specifications

Discharge size range: 100mm to 450mm [4" to 18"]

Flowrates to: 4000m³/hr [17,600GPM]

Heads to: 80m [260ft]

Key Features:

Enhanced performance - lower costs

The strength of CNSME products lies in the superiority of our hydraulic designs and wear and corrosion resistant materials.

Enhanced abrasion resistance - longer life

A variety of new advanced alloys, including Hyperchrome A61 provide enhanced abrasion resistance for the most arduous of applications.

Enhanced efficiencies - lower energy costs

The SG, SGH pumps are fitted with high performance impellers with substantially enhanced efficiencies.

Typical Applications

- Sand and Gravel
- Dredging
- Hydraulic Mining
- Sugar Beet
- Tunneling
- Slag Granulation

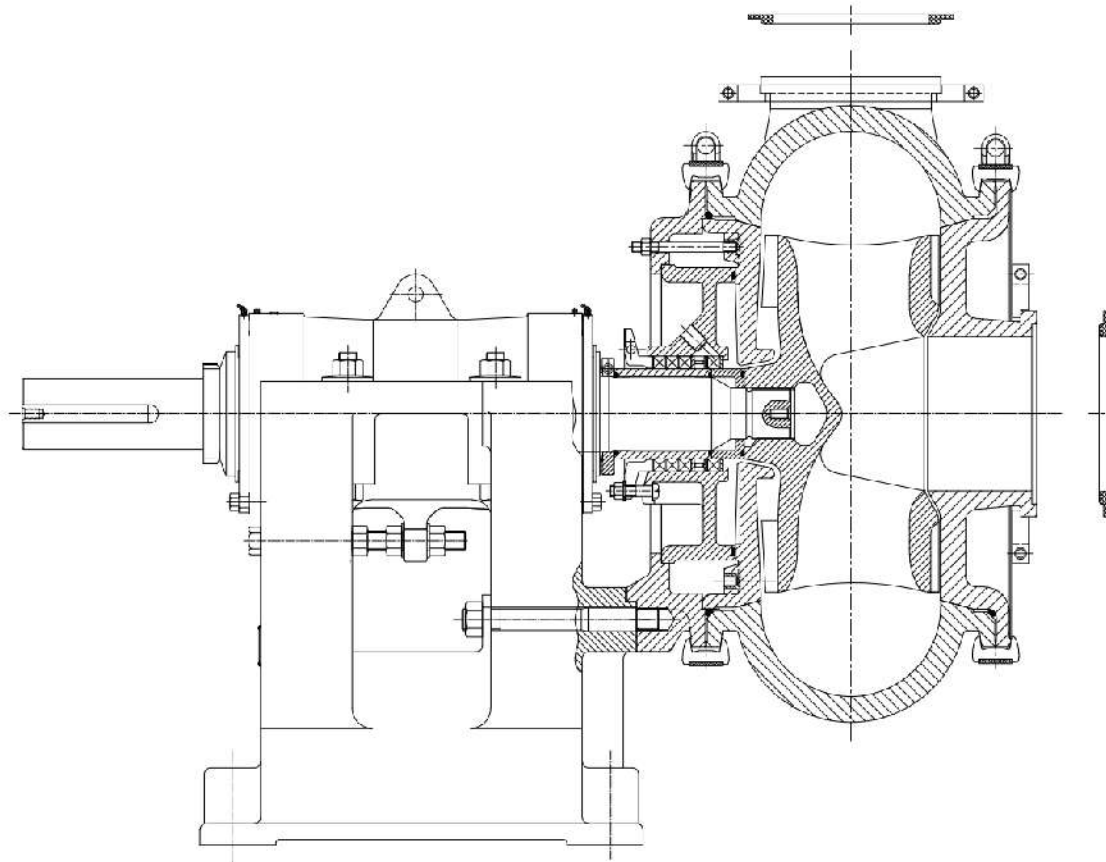

CNSME®

Centrifugal Slurry Pumps

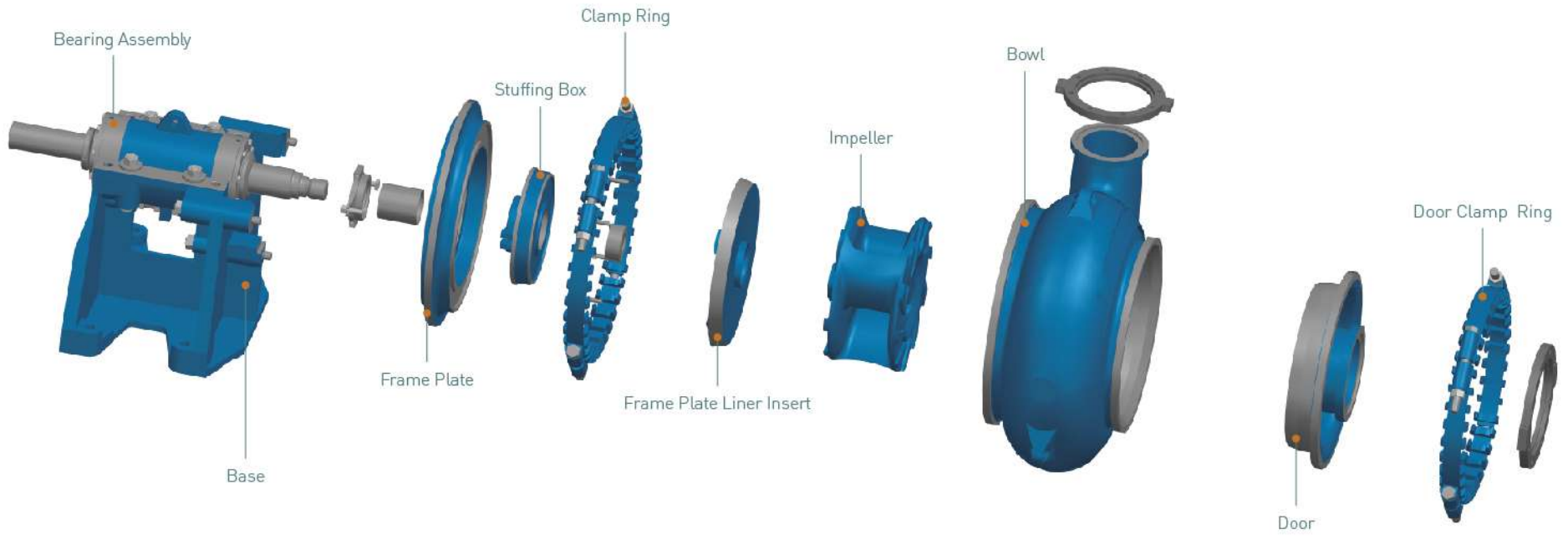

Performance Coverage for Quick Selection

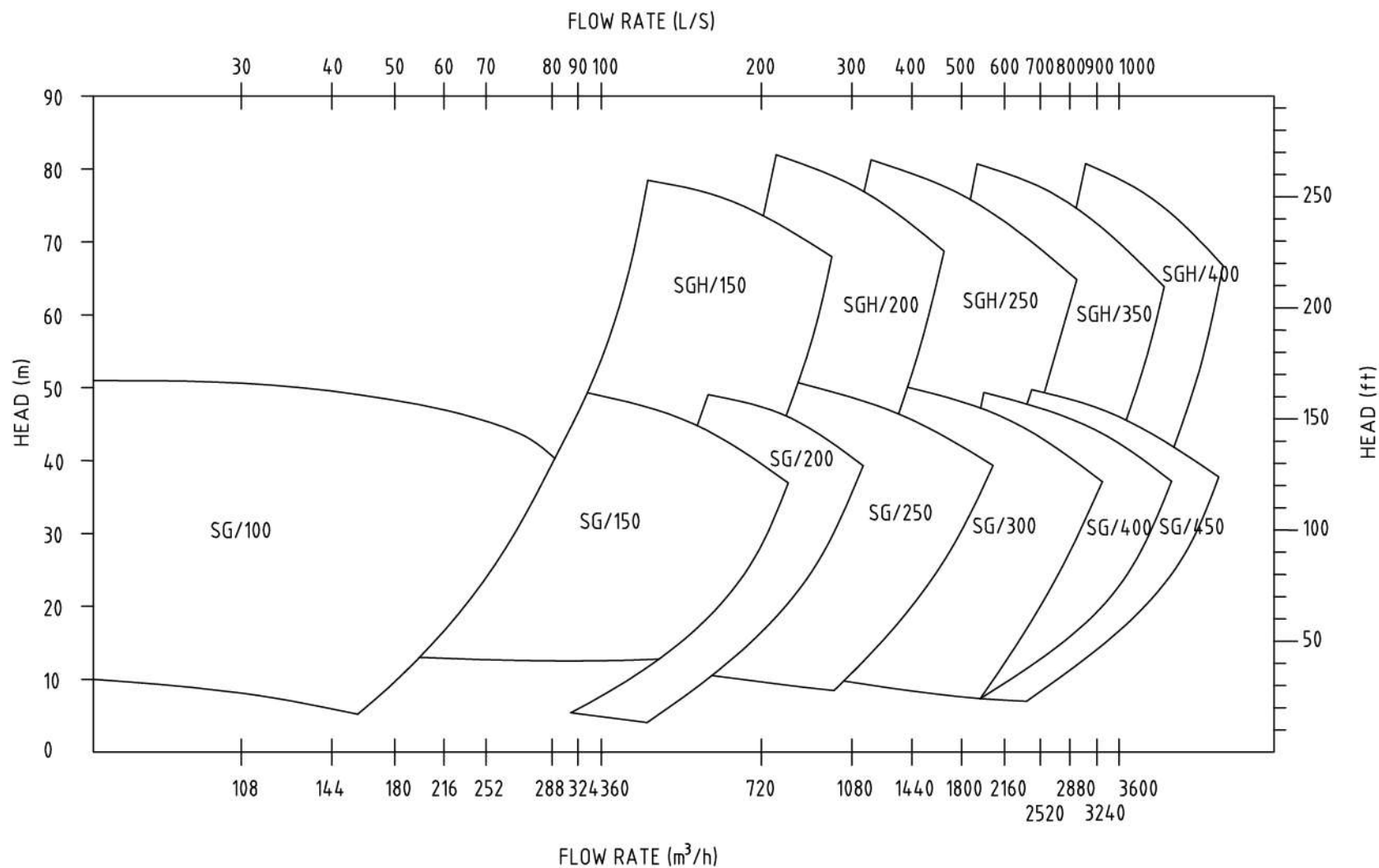

● SHF/SMF/SLF Series



Overview

The SHF/SMF/SLF range of froth pumps are designed to handle heavy froth for tough flotation froth duties, featured with a unique inlet and impeller design, this line of horizontal froth pumps is very successful where others fail.

A large oversized inlet with a unique impeller inducer blade handles heavy froth and higher viscosity dense slurries with ease. The CNSME SHF/SMF/SLF series of horizontal froth pumps has proven valuable for very dense slurries where viscosity starts to become a pumping issue for the standard slurry pump.

Specifications

Discharge size range: 50mm to 550mm [2' to 22']

Flowrates to: 4550m³/hr [20,000GPM]

Heads to: 37m [120ft]

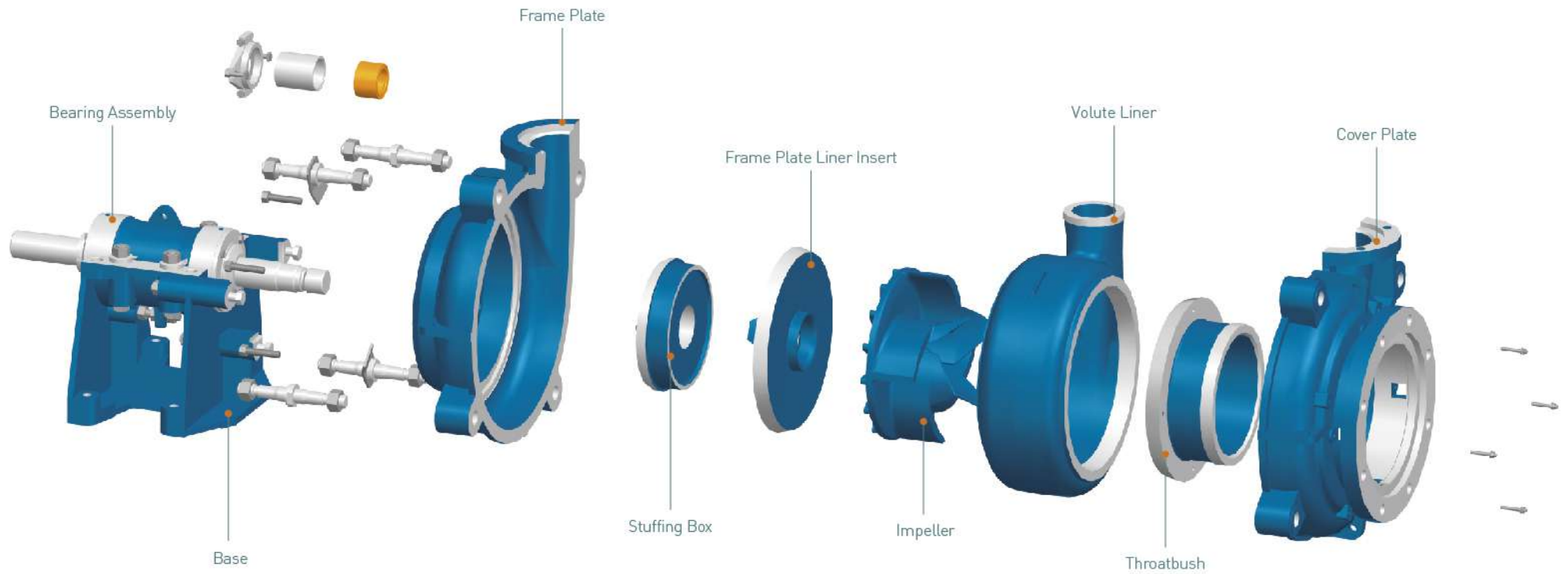

Performance Coverage for Quick Selection

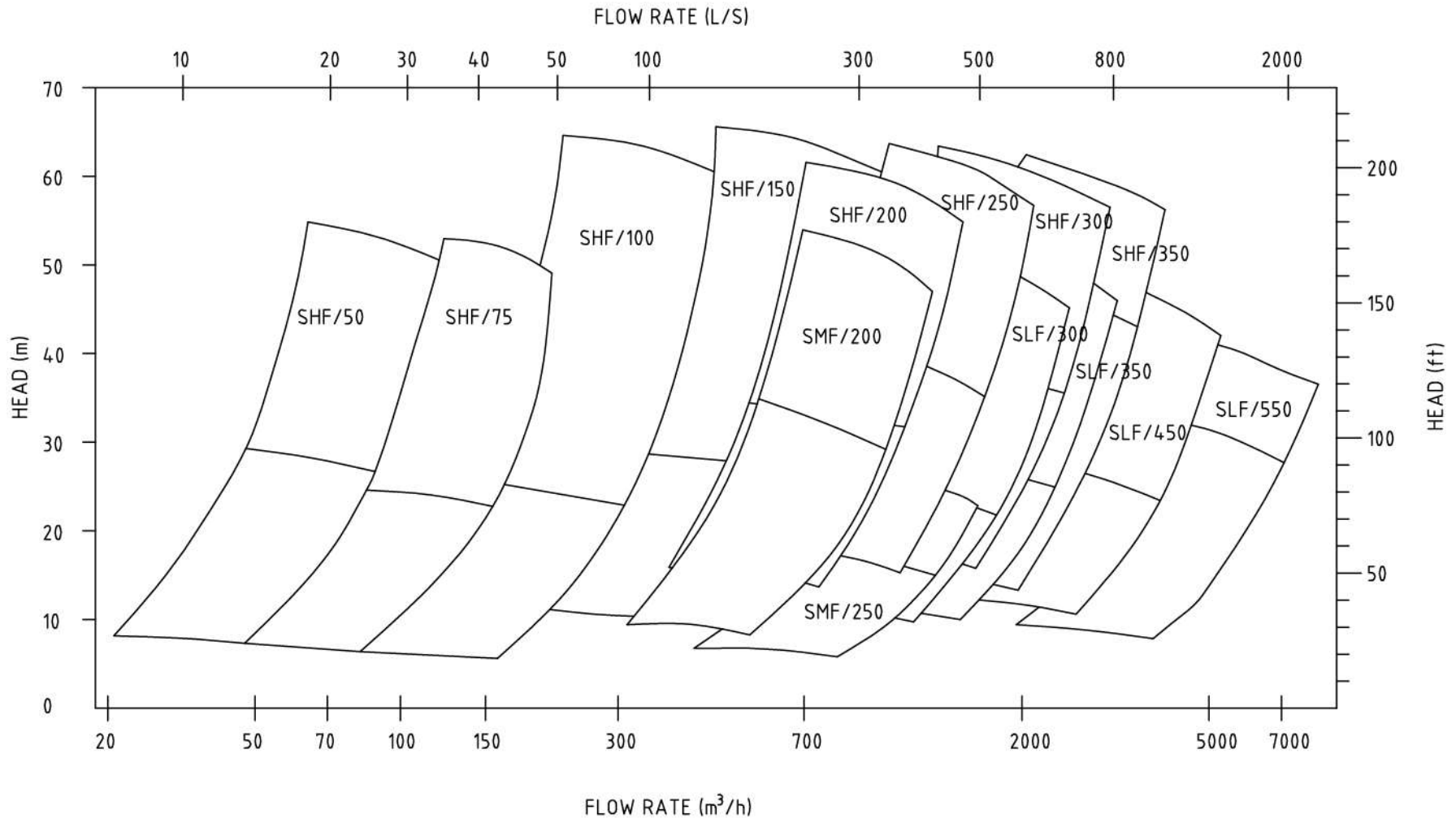

Key Features:

Heavy duty construction with through-bolt design provides ease of maintenance and minimal downtime

Large diameter, slow turning, high efficiency impellers designed to achieve maximum wear life and low operating costs

Large, open internal passages designed to reduce internal velocities, maximize wear life and lower operating costs

Unique impeller design for most difficult froth applications

Thick elastomer or alloy bolt-in liners provide superior corrosion resistance plus offer ease of liner change-out and interchangeability to reduce overall maintenance costs and maximize wear life

Minimal shaft/impeller overhang reduces shaft deflection and increases packing life

Cartridge-style bearing assembly allows for maintenance in a clean environment without removal of the pump, resulting in reliable operation and prolonged bearing life

Standard SH and SL pumps can be converted by replacing cover plate, throatbush and impeller

Typical Applications

- Minerals Concentrate
- Mineral Sands
- Flotation
- Fine Tailings

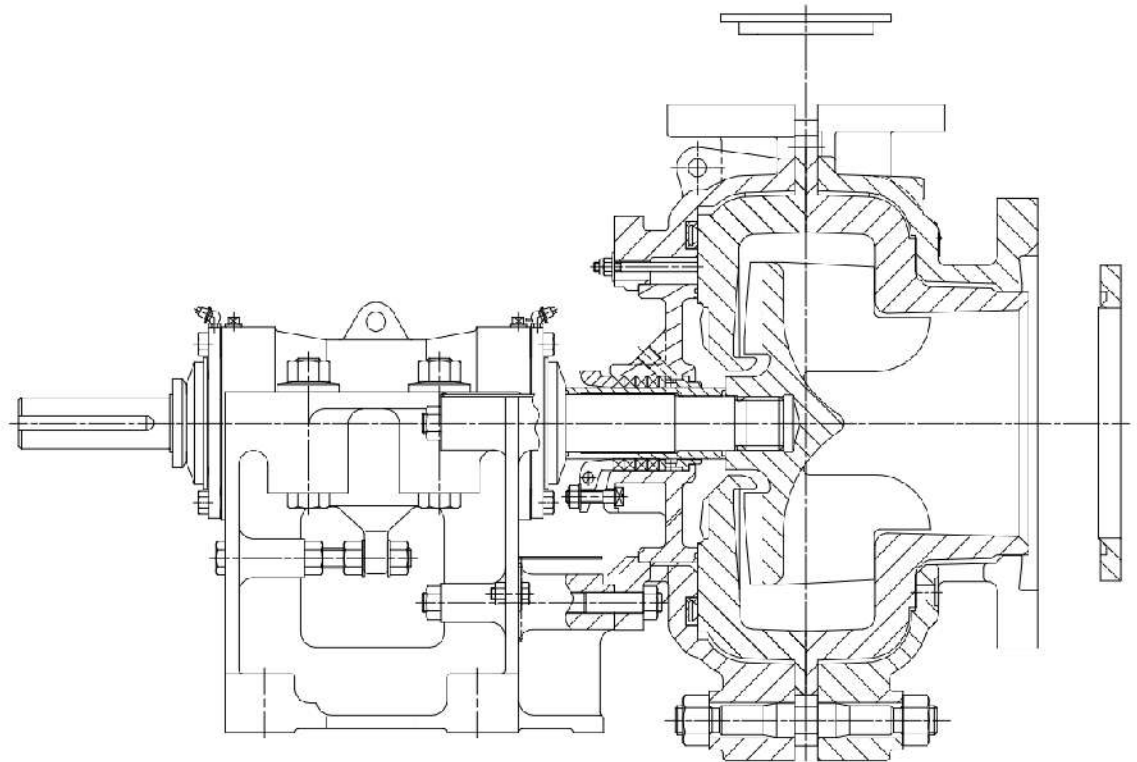

● MD Series

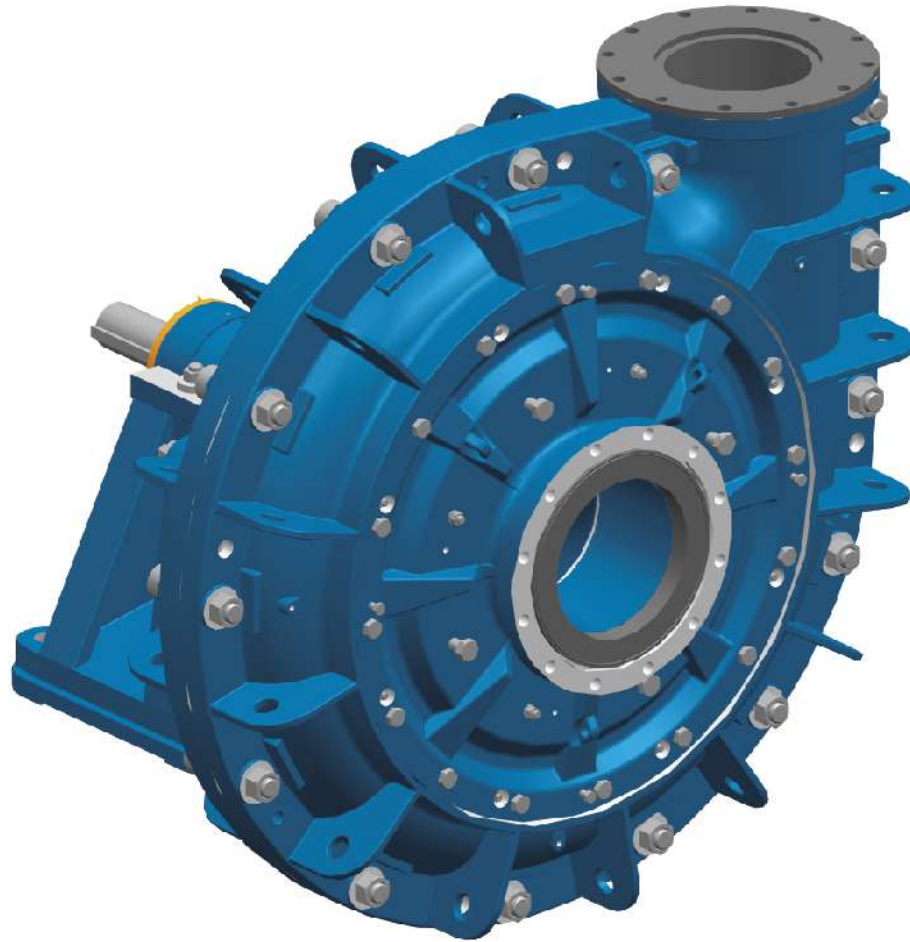

Overview

The mill underflow duty MD pump range is specifically designed for the most aggressive and coarse applications such as ball mill cyclone feed and water flush crushing in mineral processing plants. The MD pumps easily manage large size particles in dense abrasive slurries and offer the right combination of ruggedness, durability, hydraulics and materials.

Specifications

Discharge size range: 125mm to 750mm [5" to 30"]
Flowrates to: 17000m³/hr [74,790GPM]
Heads to: 60m [197ft]

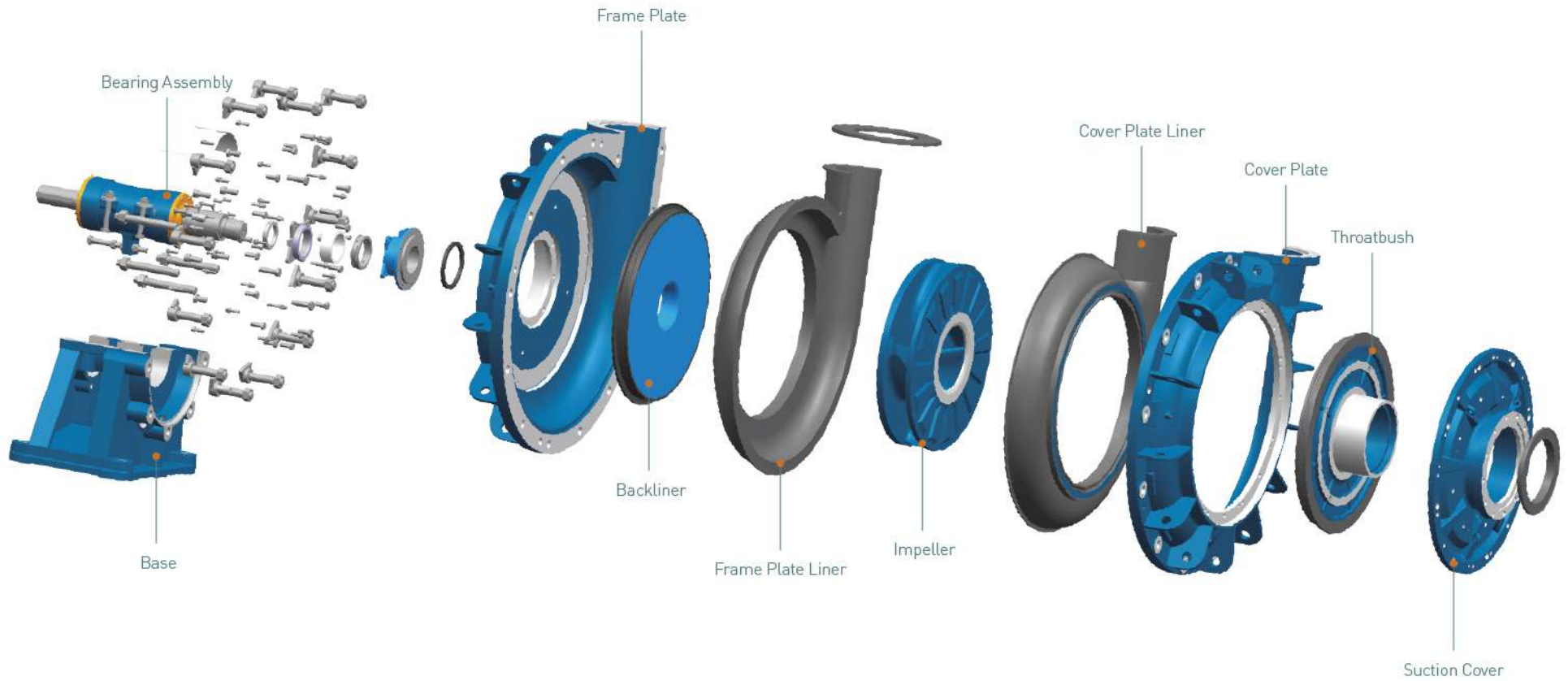

Performance Coverage for Quick Selection

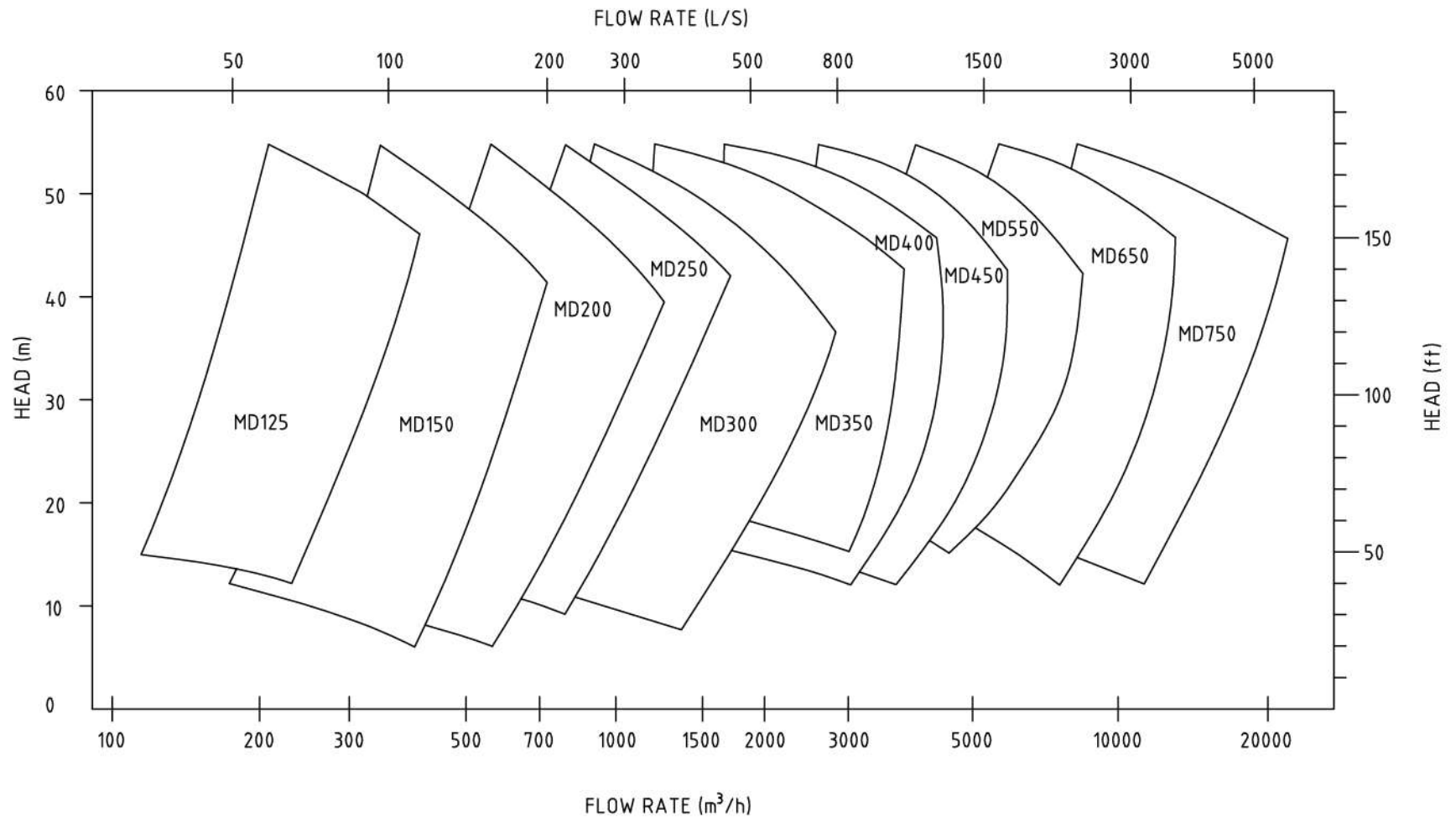

Key Features

Large diameter, low speed, high efficiency impellers manufactured from a range of abrasion resistant hard alloys provides increased wear life

Unique design and excellent hydraulics ensures high performance efficiency

4-vane, large open impeller internal passages allow for larger particle passing

Latest wear resistant materials combination optimizes component performance

Interchangeable metal or elastomer liners provides ease of maintenance

A large diameter shaft with the shortest possible over hang and heavy duty roller bearings housed in a removable bearing box extends bearing life

Impeller release collar facilitates the impeller removal

Simple full face side liner adjustment allows the liner to move closer to the impeller face to minimize the impeller-throatbush gap and to extend wear life

Fast one-piece wet-end change-out on larger sized pumps ensures minimum mill downtime to save time and money

Available pump body reverse rotations allows for both right vertical (standard) and left vertical (optional) discharge positions to offer plant design flexibility

Typical Applications

- Coarse Tailings
- Dredging
- Wet Crushers
- Minerals Concentrate
- Coal
- Mill Discharge

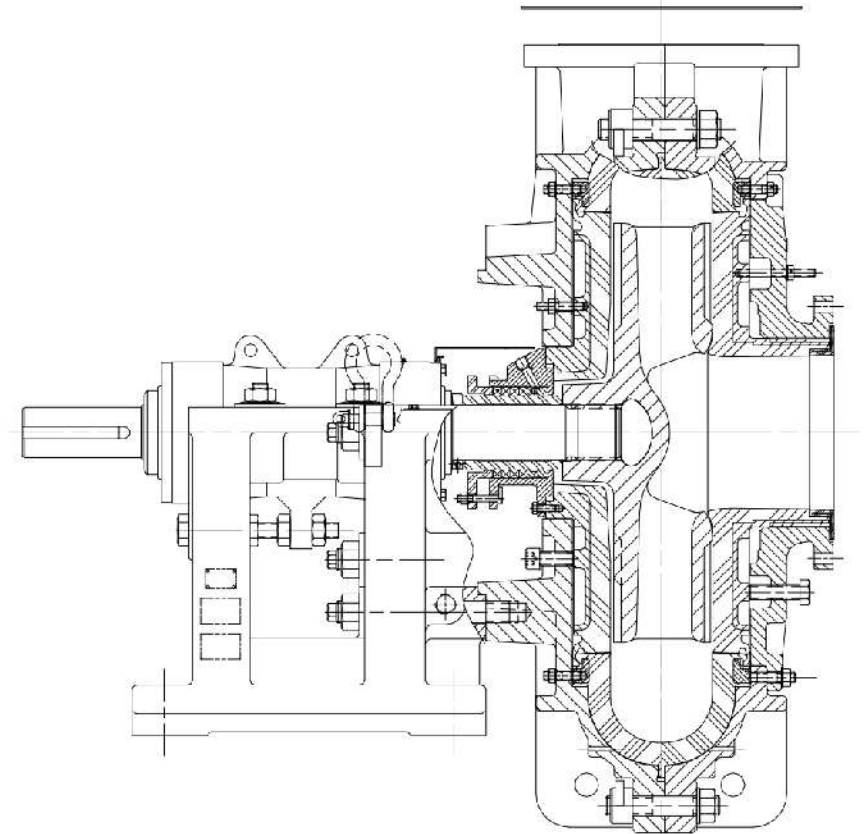

● SV(R) Series

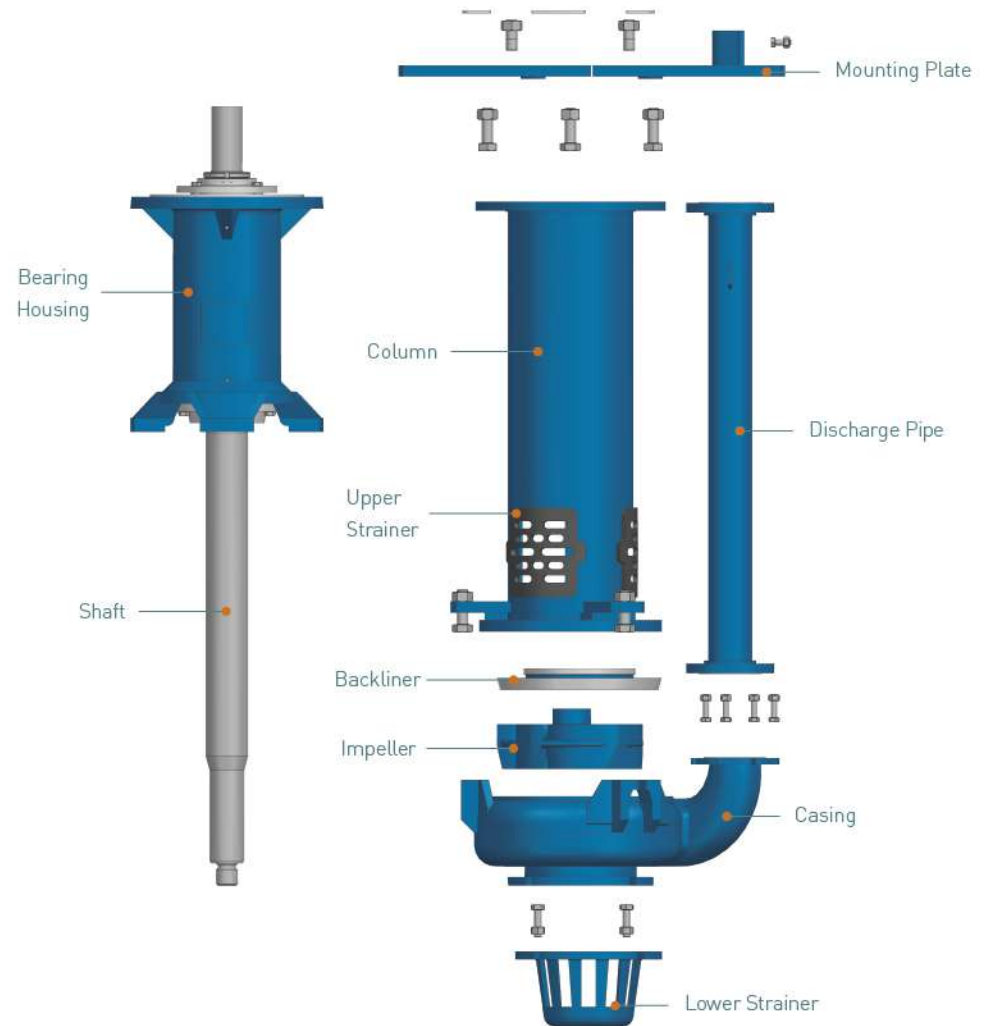
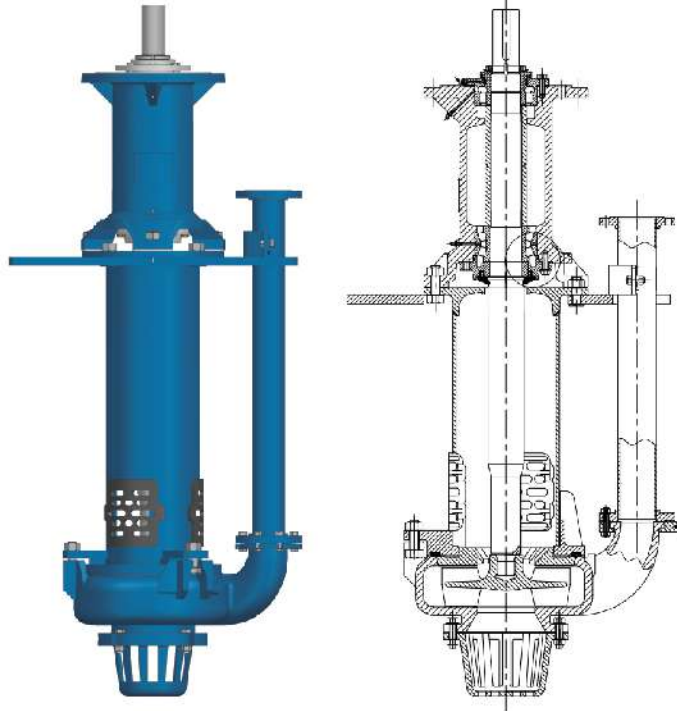

Overview

The SV/SVR pump range is heavy duty cantilever abrasion/corrosion resistant sump pump designed for extended wear life, reliability and durability. The heavy duty cantilever design makes the SV/SVR sump pump an ideal suit for continuous handling of abrasive and corrosive slurries with the pump half submerged in sumps or pits.

Specifications

Discharge size range: 40mm to 300mm [1.5" to 12"]
Flowrates to: 1000m³/hr [4,400GPM]
Heads to: 55m [180ft]

Key Features

- Wetted components are available in a wide range of abrasion resistant high chrome alloys, corrosion resistant stainless steels and natural and synthetic elastomers
[To suit special requirements, wet ends of SH(R) pumps can be fitted to SV(R) pump dry end]
- Heavy duty roller bearings installed above mounting plate protect the pump from submerged bearing failures
- No shaft seal is required due to the vertical cantilever design
- Suction strainer fitted inlet combined with the open impeller large passages reduce blockages risk

Typical Applications

- Minerals Processing
- Effluent Handling
- Coal Preparation
- Sand and Gravel

Performance Coverage for Quick Selection

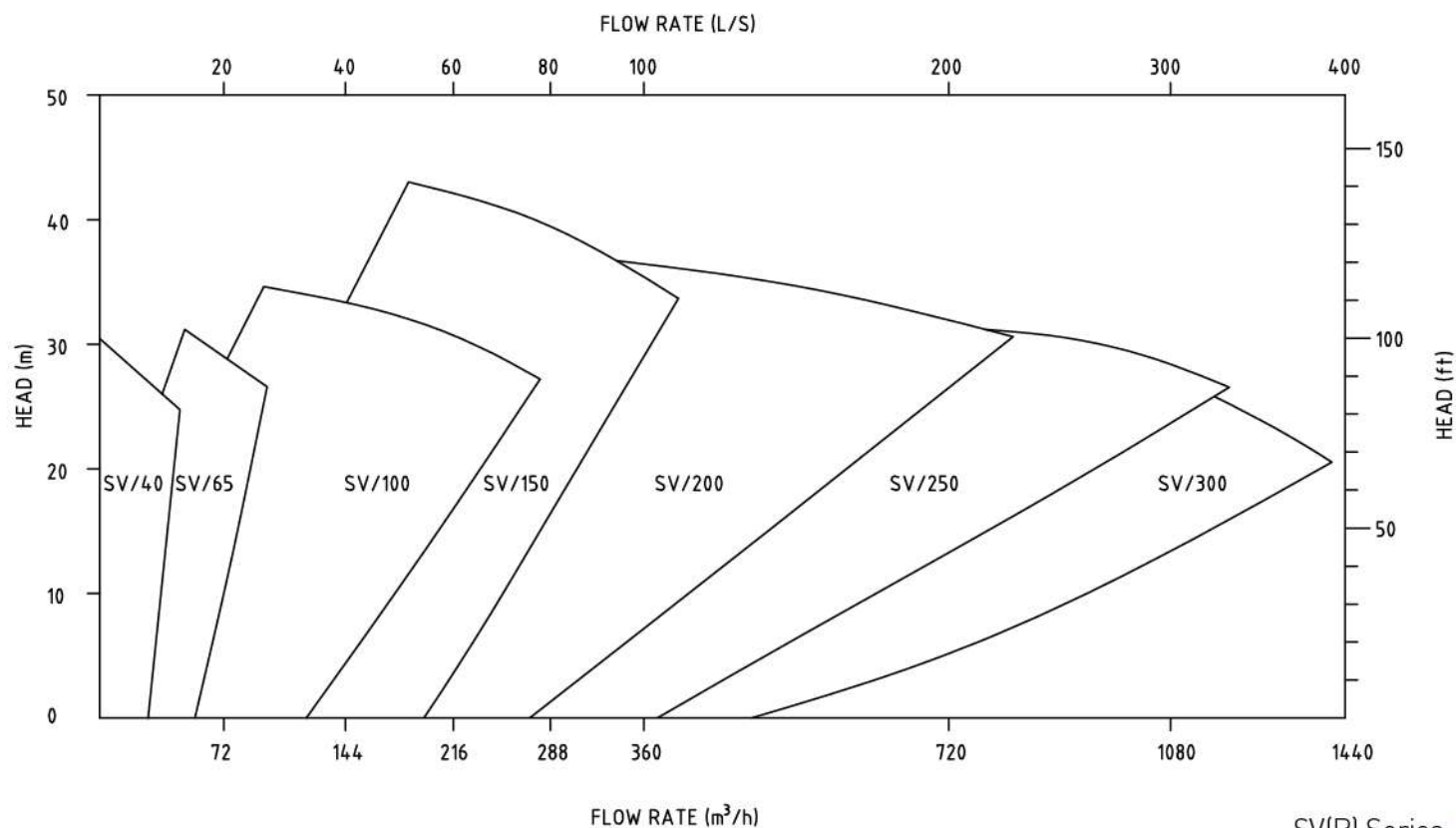

CNSME®

Centrifugal Slurry Pumps

● STC Series

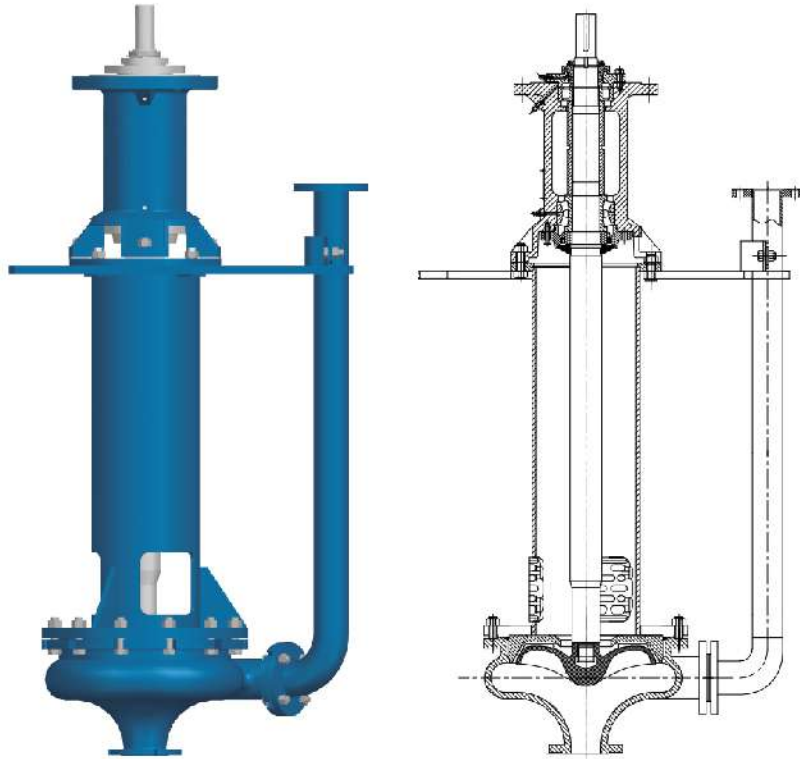

Specifications

Discharge size range: 50mm to 250mm [2" to 10"]

Flowrates to: 1600m³/hr [7,000GPM]

Heads to: 31m [100ft]

Overview

The STC range of pumps is designed specifically for continuous use in slurry applications with larger or breakage sensitive particles. This series of unlined vortex pumps is capable of handling both large and very soft particles, especially where particle degradation is of concern. The large volume internal profiles, combined with the recessed open impeller design, reduce particle interaction and limit potential blockages.

The recessed impeller design, together with the large volume casing, has allowed the impeller vanes to be positioned outside of the general flowpath of the fluid. This results in the pump's large particle handling capability as well as very low particle degradation due to the limited vane interaction with the medium being pumped.

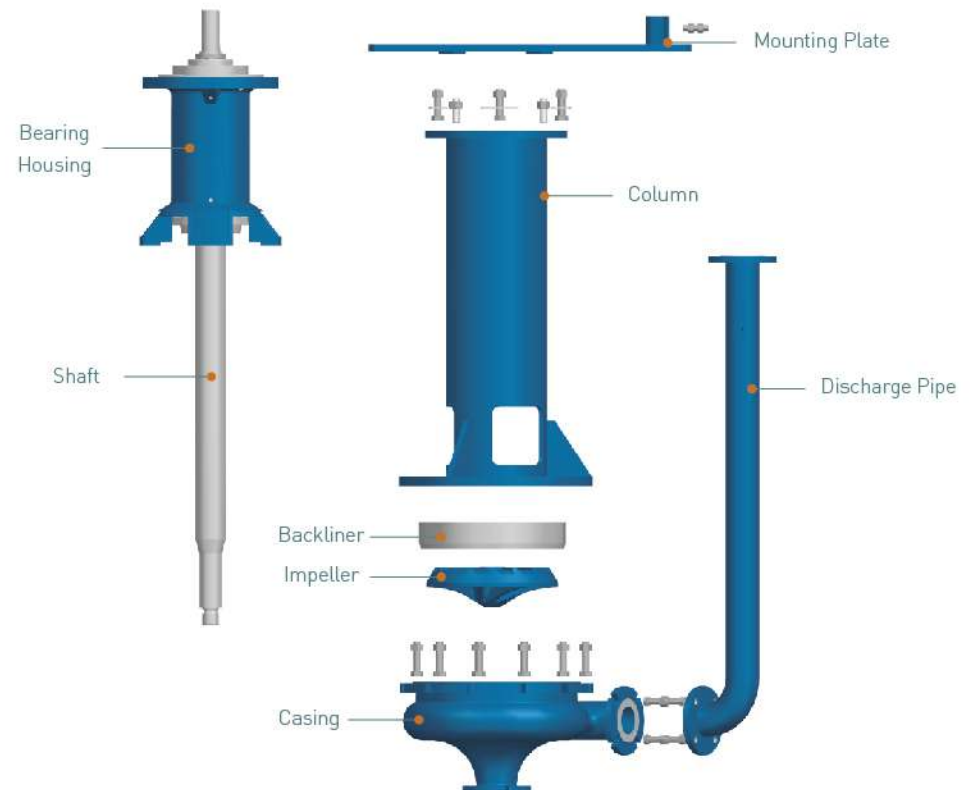

Key Features

All Metal Wet-end Components

The unlined all-metal design of the wet-end components is suitable for both horizontal and vertical configurations.

Recessed Impeller

The unique recessed impeller design sets up an internal vortex, which transfers the energy to the medium being pumped. This soft transfer of energy limits the amount of particle degradation significantly when compared to conventional pumps.

Same Inlet and Outlet Sizes

Equally sized inlets and outlets determine the maximum particle size that the pump can handle limiting potential blockages that could arise when pumping large particles.

Large Volume Casing

The large volume casing design reduces velocities further decreasing wear and particle degradation.

Heavy Duty Robust Bearing Assembly

Robust bearing assemblies, consisting of heavy-duty taper rollers, minimum shaft overhang and rigid large diameter shafts contribute to trouble free operation on both horizontal and vertical configurations.

Various Shaft Lengths

Availability of vertical spindle arrangements is standard and shaft lengths vary as per the normal CNSME SV and SVR pump ranges.

Typical Applications

- Carbon Transfer Duties
- Sewage and Effluent
- "Soft" Particles
- Low Shear Duties
- General Spillage
- Diamond Concentrate

Performance Coverage for Quick Selection

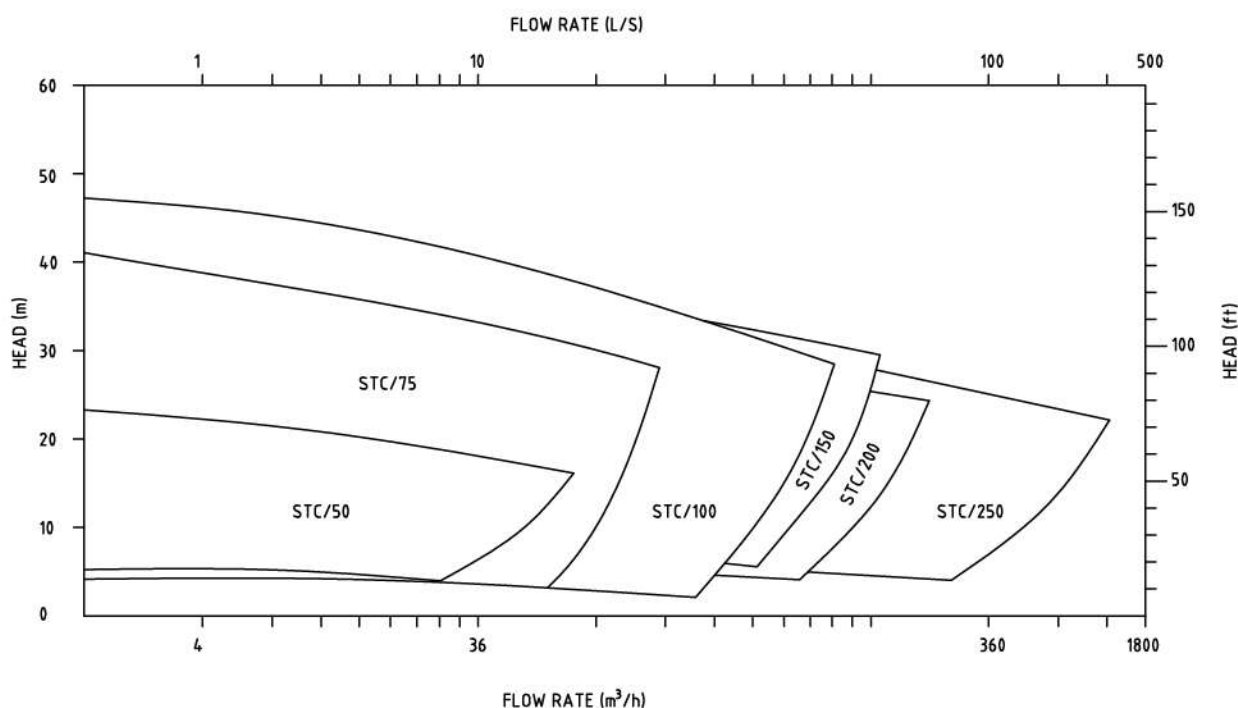

CNSME®

Centrifugal Slurry Pumps

● SF Series

Overview

The SF pumps are designed to increase the pumpability of frothy slurry. Air is separated from the slurry in a vortex created by the impeller rotation and the tangential inlet to the pump's conical sump. This results in more efficient pumping at higher capacities and a smooth operation, free from pulsations caused by air locking.

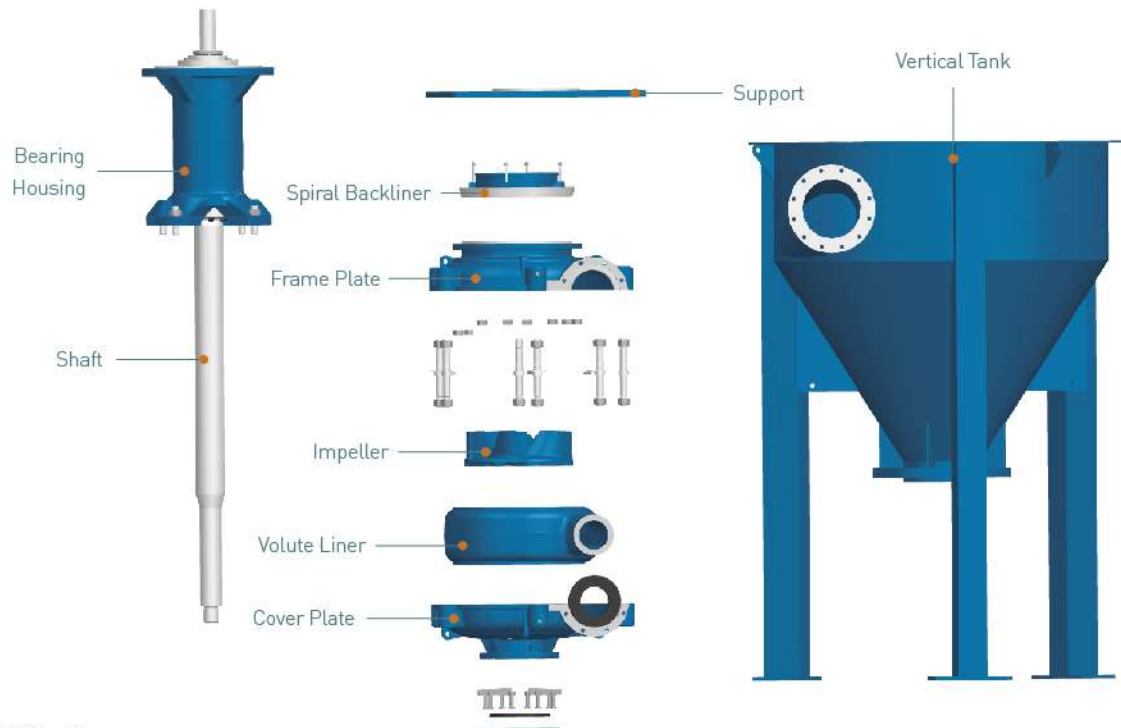
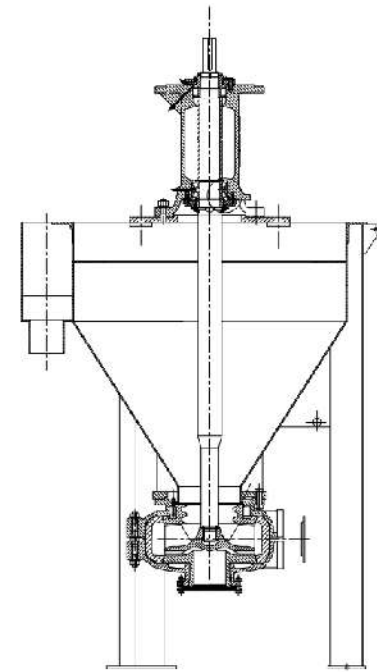

Specifications

Discharge size range: 50mm to 200mm [2' to 8"]

Flowrates to: 570m³/hr [2,500GPM]

Heads to: 30m [98ft]

Key Features

- Integrated unit for layout flexibility
- Smooth operation of the open vortex created in the sump and vertical “wet end” inlet prevents air locking
- Cantilever design does not require submerged bearings or shaft seals
- The conical tank design with its tangential inlet creates an open vortex
- Wear resistant wet-end parts guarantees a long performance life
- Pump shaft is carried in grease lubricated anti-friction bearings.

Typical Applications

- Mineral Froth
- Phosphate Washing Plants
- Copper Preparation
- Flotation Process

Performance Coverage for Quick Selection

